



ID-3uP, ID-12uP, ID-20uP

Micro-Power Modules

Advanced RFID Reader Technology

Datasheet Version 1.1 Date 28/02/15



Content

1.ID-xxuP Features	4
2.Device Overview	4
3.Pin Outs	4
3.1 Pin Out for ID-3uP, ID-12uP, ID-20uP Modules.....	4
3.2 Pin Description & Data Formats ID-12uP, ID-20uP Modules	5
3.3 Pin Detail ID-3uP, ID-12up and ID-20uP	5
4.Test Circuit.....	8
4.1 Test Circuit for ID-12/20uP Modules	8
4.2 Test Circuit for ID-3uP Modules.....	9
5. Data Formats	9
6. Magnetic Emulation Waveforms.....	10
7. Compatibility Issues	11
8. Design Considerations	11
8.1 Supply Voltage and Host Data Logic Input.	11
8.2 Response Times and Current Drain.....	11
8.3 Cards Left in Read Range	12
8.4 Reader Smart Response	12
8.5 Interference and Switching Converters.....	12
8.6 Beeper Selection	13
8.7 Module Active and Read LEDs.....	13
8.8 Host Input Impedance	13
8.9 Response Time and Output Format Selection	13
8.10 Using Data Transmitters.....	13
8.11 PCB Layout, Earthed Planes and Tracking	14
8.12 Regulator Characteristics and Filtering	14
8.13 External Circuitry and Battery Loading.....	14
9. Setting the Output Format.....	14
10. Setting the Activation Time.....	15
11. Device Specifications	15
12. Starting Up the ID-12uP	16

13. Absolute Maximum Ratings	16
14. Designing Coils for the ID-3uP	16
15. Tuning the ID-3uP (External Antenna)	17
16. DC Characteristics	18
17. Useful information	19
18. Case Dimensions for ID-xxuP.....	20
19. Contact Information	21
20. Important Safety Notice	21
Disclaimer.....	21

1.ID-xxuP Features

- **Ultra-Low Power – as low as 15 micro-watt**
- **Ideal for both Fixed and Portable Readers**
- **May be powered from a single 3v Lithium Button Cell or solar cells**
- **Broadly compatible with existing ID-xx series modules.**
- **Programmable Output Format**
- **Programmable Power/Response**
- **Small Footprint**
- **Low Cost**

2.Device Overview

ID-Innovations ID-3uP, ID-12uP and ID-20uP are ultra-low power modules designed to operate from 3volt lithium cells offering a power saving of about 20,000x over standard 12volt readers. At its lowest power setting is consumes just 15 μ W. ID-xxuP modules enable a host of new RFID solutions. At the lowest power setting the average read time is 3seconds and the typical current at 3volts is <10 μ A making the modules ideal for cabinets, sheds, boats, caravans, toolboxes, safes and portable readers. The modules may be programmed for ASCII, Wiegand and Magnetic Emulation output formats. There are four selectable power settings that correspond to the scanning period. At the highest power setting the average read time is 180mS and the current drain is <180 μ A making these modules the perfect low power alternative to conventional readers. The ID-xxuP series are compatible in most respects with the ID-3, ID-12 and ID-20 series modules.

3.Pin Outs

3.1 Pin Out for ID-3uP, ID-12uP, ID-20uP Modules

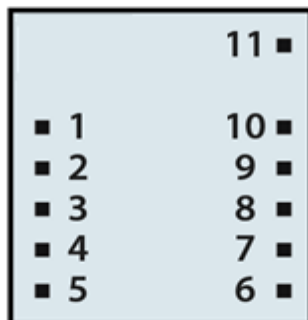

Bottom View



3.2 Pin Description & Data Formats ID-12uP, ID-20uP Modules

Pin#	Description	ASCII	Magnet Emulation	Wiegand26
Pin 1	Zero Volts	GND 0V	GND 0V	GND 0V
Pin 2	Do not connect			
Pin 3	Do not connect			
Pin 4	Activity LED	Activity LED	Activity LED	Activity LED
Pin 5	Magnetic Mode CP Out	No function	Card Present*	No function
Pin 6	Scan Period Select	Scan Period Select	Scan Period Select	Scan Period Select
Pin 7	Format Select	Strap to GND	Strap to Pin 10	Strap to +5V
Pin 8	Data 1	CMOS	Clock*	One Output*
Pin 9	Data 0	TTL Data (inverted)	Data*	Zero Output*
Pin 10	Tag Read Logic	Beeper / LED Logic	Beeper / LED Logic	Beeper / LED Logic
Pin 11	DC Voltage Supply	+Vdd	Vdd	Vdd

*In Wiegand and Magnetic emulation modes data outputs are configured as common drain and an internal pull-up is internally provided by the module. This may be suitable for most applications, however in some circumstances an additional 4K7 pull-up resistor to +Vdd may be required.

3.3 Pin Detail ID-3uP, ID-12uP and ID-20uP

Pin1 is zero volts and communications ground. The copper connections to the pin should be robust, however using a ground plain that extends under the module antenna is not advisable as it will become an RF shorted turn causing detuning and loss of range. Care must be taken to route the supply tracks away from any regulator smoothing capacitors as these can crowbar a lot of noise current and cause noise pickup in adjacent antenna leads. Ideally the ground and the supply leads should be placed opposite each other on each side of the board up to the point of meeting the Module.

Pin2 is not used. As a compatibility issue, no harm will occur if the pin is wired to pin11. Regular ID-3/12/20 series have this pin connected to pin11 although it is advisable to leave it blank. Unlike the ID-3/12/20 series, pin2 cannot be used to reset the module.

Pin3 is only used on the ID-3uP for connection to an external antenna and should be left unconnected on ID-12uP and ID-20uP modules. The antenna connections should not pass under

or near power chokes or regulator smoothing capacitors which can crowbar a lot of noise current and induce this noise pick-up into adjacent antenna leads. If possible place the copper tracks on opposite sides of the PCM so that they are positioned dead on top of each other.

Pin4 is used on all modules, ID-3uP, ID-12uP and ID-20uP for the Activity indication LED. The LED should be driven by a resistor no less than 4K7. This LED will flash at the start of each read scan and the flashes will correspond to the chosen Scan Period. Due to the low power, a high brightness/efficiency LED is strongly recommended.

The ID-3uP uses pin4 in a dual fashion since it is also the return pin for the external antenna. Antenna connections should not pass under or near power chokes or regulator smoothing capacitors, as these can crowbar a lot of noise current which can induce pick-up noise into adjacent antenna leads. If possible place the copper tracks to the external antenna on opposite sides of the PCM so that they are positioned dead on top of each other.

Pin5 is only used in magnetic emulation mode as the 'Card Present' output and is only functional when magnetic emulation is selected. In this mode it is normally high. See magnetic emulation waveforms, chapter6. The output is open drain and has an internal pull-up, however in some applications an external pull-up resistor connected to pin11 may be required. A 10K is normally suitable.

Pin6 is the power setting select pin. For 6second scan, connect to pin11, for 2second scan, connect to pin1, for 750mS scan connect to pin10 and for 250mS scan connect to pin9. Never leave this pin floating or excessive power may be drawn.

Pin7 is the output format select pin. For ASCII connect to pin1, for Wiegand connect to pin11, for Magnetic ABA track2 emulation connect to pin10. Never leave this pin floating or excessive power may be drawn.

Pin8 is used as for ASCII and Wiegand outputs. When ASCII mode is selected the output is full CMOS. When Wiegand mode is selected it is configured as an open drain output with an internal pull-up. The internal pull-up will normally be sufficient but in some Wiegand applications an external pull-up resistor may also be required. A 10K is normally suitable.

Pin9 is used as for ASCII and Wiegand outputs. When ASCII mode is selected the output complementary to pin8 and is also full CMOS. When Wiegand mode is selected it is configured

as an open drain output with an internal pull-up. The internal pull-up will normally be sufficient but in some Wiegand applications an external pull-up resistor may also be required. A 10K is normally suitable

Pin10 is the read-card logic normally low output. The pin delivers a DC 100mS pulse after a read. It should only be connected to an LED through a resistor greater than 4K7 or a suitable FET driver. The beeper power should be kept low as excessive current may reduce the lithium battery voltage below the modules minimum working value, especially as the battery ages. See 'Design Considerations and Tips'

For compatibility, note that the ID-3, ID-12 and ID20 series use a 100mS pulse modulated at 3KHz. The beeper for the ID-xxuP series modules should be 3volt DC working with internal circuitry for the Piezo tone.

Pin11 is the VDD positive supply pin. The module is rated at +2.6 volts thru +3.5 volts. Ideally the copper tracking up to supply pins, 11 & 1, should be placed opposite each other, one on each side of the board. If the module power supply is mains derived, a 1uF ceramic X7R capacitor across pins 1 & 11 is recommended. If the module is battery powered the user may consider fitting a larger capacitor, up to 470uF because as the battery is used the internal impedance increases. The larger capacitor can sustain the supply voltage during the scan cycle when currents peak. This may extend the usable battery life. In any event, the supply voltage must be maintained above the minimum ID-xxuP supply voltage, 2.6volts, or the module may become erratic.

4. Test Circuit

4.1 Test Circuit for ID-12/20uP Modules

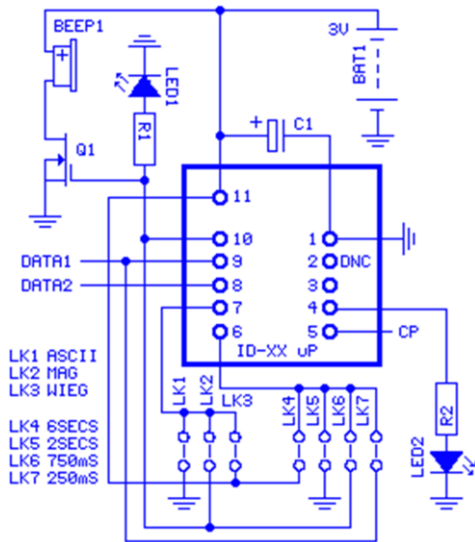

Part	Description
R1,R2	4K7
C1	100uF, 10V
Q1	2N7002 or similar
LED1, LED2	High Efficiency
LK1,LK2,LK3,LK4,LK5,LK6,LK7	Links
Beep1 - See Note1 below	3V DC Beeper
ID-XX uP	ID12-uP/ID20-uP
Bat1	3 Volt Lithium Cell

Note1 - Users are warned that Beep1 must be low power and may only be used in conjunction with a **substantial** battery, not a lithium button cell, or the uP module may misbehave.

4.2 Test Circuit for ID-3uP Modules

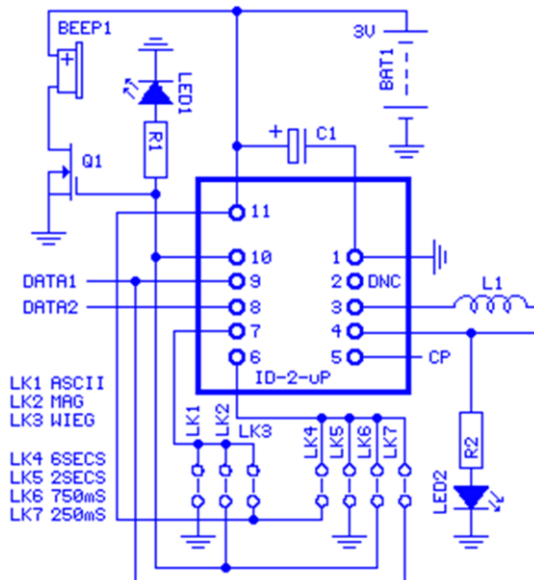

Part	Description
R1,R2	4K7
C1	100uF, 10V
Q1	2N7002 or similar
LED1, LED2	High Efficiency
LK1,LK2,LK3,LK4,LK5,LK6,LK7	Links
Beep1 - See note2 below	3V DC Beeper
ID-XX uP	ID12-uP/ID20-uP
Bat1	3 Volt Lithium Cell
L1	1.34mH

Note2 - Users are warned that Beep1 must be low power and may only be used in conjunction with a **substantial** battery, not a lithium button cell, or the uP module may misbehave

Also see Appendix A for circuit diagram and PCB layout of the ID-Innovations *Demo reader* for ID-xxuP and ID-xxuP-SA series modules.

5. Data Formats

Output Data Structure - ASCII - 9600 Baud, No Parity, 1 stop bit.

Output = CMOS (Push Pull) 0-5v

STX (02h)	DATA (10 ASCII)	CHECK SUM (2 ASCII)	CR	LF	ETX (03h)
-----------	-----------------	---------------------	----	----	-----------

Example for Calculation of Checksum for Output type '1'

Suppose the output Data is 0C000621A58E

Here the actual data is 0C,00,00,06,21,A5 and the checksum is 6E

Using binary we Exclusive OR the bit columns

0C	=	00001100
00	=	00000000
06	=	00000110
21	=	00100001
A5	=	10100101

CHECKSUM = 10001110 = 8E

Output Data Structure - Wiegand26 – 1mS repeat, 50uS pulse. Open Drain

1	2	3	4	5	6	7	8	9	10	11	12	13	14	15	16	17	18	19	20	21	22	23	24	25	26	
P	E	E	E	E	E	E	E	E	E	E	E	E	O	O	O	O	O	O	O	O	O	O	O	O	O	P
Even parity (E)													Odd parity (O)													

P = Parity start bit and stop bit

Output Data Magnetic ABA Track2 – At Approx. 80cm/sec. Open Drain

10 Leading Zeros	SS	Data	ES	LCR	10 Ending Zeros
------------------	----	------	----	-----	-----------------

[SS is the Start Character of 11010, ES is the end character of 11111, and LRC is the Longitudinal Redundancy Check.]

6. Magnetic Emulation Waveforms

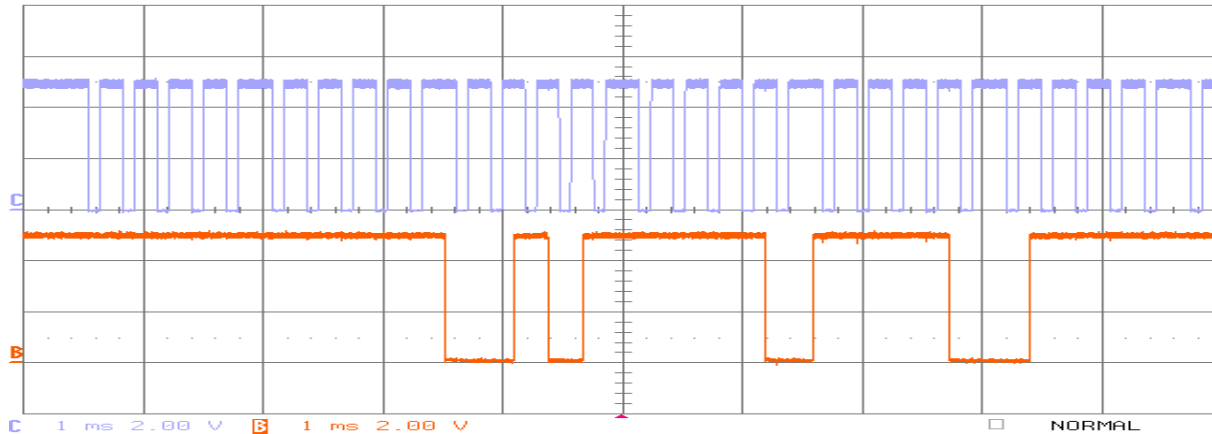

Blue = Clock, Brown = Dat

Fig. 3 Magnetic Emulation

Start and End Sequences for Magnetic Timing

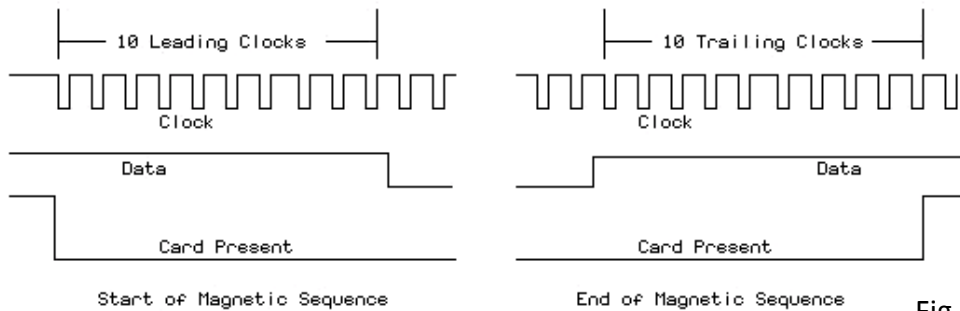

Fig. 4 Magnetic Emulation

Data Timings for Magnetic Emulation

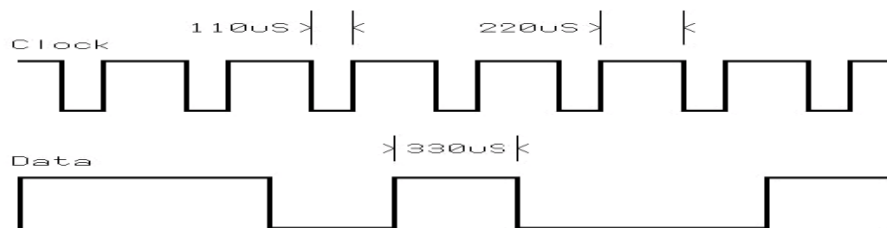

Fig. 5 Magnetic Emulation

The magnetic Emulation Sequence starts with the Card Present Line going active (down). There next follows 10 clocks with Zero '0' data. At the end of the 10 leading clocks the start character (11010) is sent and this is followed by the data. At the end of the data the end character is sent followed by the LCR. Finally 10 trailing clocks are sent and the card present line is raised.

The data bit duration is approximately 330uS. The approximate clock duration is 110uS. Because of the symmetry data can be clocked off either the rising or falling edge of the clock.

7. Compatibility Issues

The ID-xxuP series are broadly compatible with the ID-3, ID-12, ID-20, ID-3LA, ID-12LA and ID-20LA. The output mode selection, the data formats and the data and power supply pin-outs are identical however there are some differences in both functionality and pin use as follows

- 1) When a card is in read-range the reader module will send the card data at the end of every scan period. If a card is left permanently in read-range the ID-xx series will only send the data once.
- 2) The Read range is less, generally about 1/3 the ID-xx series range.
- 3) Pin2 was formally internally connected to the reset pin. In the ID-xxuP series this pin should be left blank for future compatibility.
- 4) Pin6 was formally used on some series ID-xx modules as a 'Tag in Range' indicator. In the ID-xxuP series Pin6 is used only to select the scan period.
- 5) The ID-xxuP series use pin4 to drive an activity indicator LED.

8. Design Considerations

8.1 Supply Voltage and Host Data Logic Input.

The ID-xx-uP modules will work with a supply voltage 2.6 volts thru 3.5 volts making it ideal for use with 3volt lithium batteries or alternatively two 1.5v cells. These limits should not be exceeded. The modules output drive is derived from the supply voltage so the host must be capable of being driven by 3v CMOS data logic.

8.2 Response Times and Current Drain

The response time is selectable using links. Selecting the slowest response time gives the lowest possible current drain. When the module set to minimum current and no card is present the average current drain is guaranteed to be below 10 μ A. Since most batteries leak more current than 10 μ A, battery shelf life will probably be the dominant factor. Lithium primary cells are an obvious choice for the power source because many have a ten year shelf life.

Once a card is presented to the module, the average read time is a little over half the selected sample time, so if a sample time of 2 seconds is chosen the average read time will be a little over 1 second. ID-xx-uP modules can be selected as power saving

alternatives to standard RFID readers which typically draw 40mA or more. When the fastest response time is selected, the read time is quicker than 200mS and the current drain is less than 100µA @ 3.0, a power saving factor of about 1000x over standard 12volt RFID readers.

Note that the Output format and the response time is sensed at start-up. Changing the pin setting after start-up will have no effect until the module is switched off and on again.

8.3 Cards Left in Read Range

ID-xx-uP modules sense when a card is present. If no card is present then the module draws low power. When a card is left in range more power is used, so it is best to remove a card after it has been read. See 'Reader Smart Response'

8.4 Reader Smart Response

The modules incorporate smart protection. In all but the lowest power setting, the ID-xx-uP senses if a card has been left in read range and automatically sets the module to a lower response setting until the card has been removed. The smart response feature cannot be changed. In applications that permanently leave a card permanently in read-range the ID-xxuP module draws a maximum of 200µA when powered at 3 volts.

8.5 Interference and Switching Converters

Strong, steady RF interference should be avoided because the ID-xxuP module will constantly analyse the RF field to see if the interference is a valid card and so draw more power. The module power source will usually be a battery, so the main source of interference, the mains power supply, will not be present, however if the power source is mains derived, care must be taken if switching convertors are used. Keep switching inverters physically away from the reader module and ensure that the switching frequency is not in the region of 125Khz. Also ensure the inter modulation products and harmonics of the switching power supply field or voltage output do not include 125Khz because the interference can mimic genuine card signals. Do not use switching power supply 'Economy Modes' because these often have high hysteresis voltages that disrupt the output regulation significantly and will cause low read range.

8.6 Beeper Selection

The recommended beeper is a low power DC beeper with an integrated Piezo driver. When small lithium batteries are used the use of beepers should be avoided completely because the current can cause large swings in the battery voltage and this may lead to unpredictable module behaviour or malfunction.

8.7 Module Active and Read LEDs

LED2 pulses regularly and is used to indicate that the module is active. This LED draws very low current but it may be removed and will save one micro amp. LED1 only flashes when a card is read. It is assumed that this will be infrequently so LED1 can be robustly powered without adding significantly to the reader power drain.

8.8 Host Input Impedance

It is important that the data outputs are connected to very high impedance interfaces or excessive currents may be drawn. For example, a 10K resistance to ground on a normally high data pin, such as the ASCII complementary output, will result in an extra current drain of 30 μ A. Ideally, data outputs should be connected to CMOS inputs on the host or external control gear.

8.9 Response Time and Output Format Selection

The output format selection and the response time selection are not dynamic, they are only active when the power is first connected. That is to say that after switch-on, changing the programming links will not affect either the modules output format or the response time. To change the response time or output format the module must first be powered down and restarted with the desired links in place.

8.10 Using Data Transmitters

Inexpensive RF transmitters, such as those in the 433MHz range, may be used to connect the ID_xxuP data output to a remote controller via a suitable receiver. This type of TX module does not usually draw any power unless the input has data, so they are ideally suited for remote data links.

8.11 PCB Layout, Earthed Planes and Tracking

The PCB layout is not critical, especially when the ID-xxuP module is battery powered. The ID-12uP and the ID-20uP modules have an internal antenna that may couple inductively with the PCB. For this reason large areas of copper, such as an earthed plane, should not be left under the module or an RF voltage will be induced into the copper and a current setup in opposition to the antenna which can reduce the read range. In battery operated circuits C1 should be as close as possible to the supply pins 1 & 11. See Appendix A for details of an ID-12uP demo board PCB layout.

8.12 Regulator Characteristics and Filtering

When the module power is derived from a mains supply then a low noise 3.0v - 3v3 regulator is recommended. A small SOT23 regulator will be normally be adequate because the reader module power is low. If a common 3volt rail is used that supplies power to a processor, ensure that the supply is clean. If the 3volt supply is not clean, it is usually much, much easier to insert a 10R 220uF low pass filter on the supply to the ID-xxuP module than attempt to clean the main 3volt rail. Attempts to decouple common power rails using large capacitors may become counter-productive as the capacitor may crowbar large quantities of noise current which still induce noise via current loops into the reader modules coil.

8.13 External Circuitry and Battery Loading

The module data outputs may be used to activate external circuitry however, if small lithium batteries are used a power source they cannot supply high currents, ensure the total current is within the capability of the battery and that the terminal voltage never drops below the ID-xxuP minimum voltage requirement. If the voltage supply dips below 2.6volts, even momentarily, the ID-xxuP module may become erratic.

9. Setting the Output Format

The output format is selected by strapping pin7 as shown in the below table. Note that the ID-xxuP checks the output format upon switch-on. Subsequently strapping pin7 to another location to change the output format will only take effect after an off-on cycle.

Pin#	ASCII	Magnetic	Wiegand26
Pin 7	Strap to Pin1 (Gnd)	Strap to Pin 10	Strap to Pin11 (+5V)

10. Setting the Activation Time

The activation time is selected by strapping pin6 as shown in the below table. Note that the ID-xxuP checks the response time upon switch-on. Subsequently strapping pin6 to another location to change the response time will only take effect after an off-on cycle. The average read time will be half the activation time + 35mS. So with an activation time of 750mS the average read time will be about 410mS.

Pin#	250mS	750mS	2Seconds	6Seconds
Pin6	Strap to Pin 9	Strap to Pin 10	Strap to Pin 1 (Gnd)	Strap to Pin 11 (+5v)

11. Device Specifications

Parameter	ID-3uP, ID-12uP & ID-20uP
Frequency	125 kHz
Card Format	EM 4001 or compatible
Encoding	Manchester 64-bit, modulus 64
Current with no card @ 3v, 6Second Setting	<10 μ A, Nominal 5 μ A
Current with no card @ 3v, 2Second Setting	<26 μ A, Nominal 13 μ A
Current with no card @ 3v, 750mS Setting	<70 μ A, Nominal 38 μ A
Current with no card @ 3v, 250mS Setting	<180 μ A, Nominal 86 μ A
Voltage Supply Range	+2.6volt thru +3.5volt
ASCII Output	9600 Baud, 8Bit, No Parity
Wiegand26	Spacing 1mS, Width 50uS Nominal
Magnetic ABA Track2	80cm/S Nominal
Read Range using ID-Innovations ISO Card	3.5cm Nominal
Read Range using ID-Innovations Clamshell	5cm Nominal
Certification	CE, C-TICK, ROHS, FCC

12. Starting Up the ID-12uP

Supply power to the module should be made cleanly, avoiding bad contacts or dropouts. The ID-12uP is an ultra-low power module and to reduce its power consumption, brownout detection has not been incorporated. After switch-on care should be taken to ensure the module is operating correctly. Reading a card is one way of testing the module. When operating correctly the status LED will flash regularly. After the function check has confirmed normal operation the LEDs may be disabled by link1 and this will save an additional 1 μ A. Link1 may be made at any time to check the activity LED and subsequently disconnected if desired.

13. Absolute Maximum Ratings

Maximum voltage applied to Pin 1	Vcc +3.5v
Maximum current drawn from Pin 3 (Antenna ID-3uP)	\pm 50mA Peak
Maximum 125 KHz RF Voltage at Pin 4 (Antenna ID-3uP)	\pm 50v Peak
Maximum current drawn from any data or select pin	\pm 5mA
Maximum current drawn from Pin 10 (Beeper)	\pm 5mA
Pins 5, 6, 7, 8, 9 & 10 may not exceed	Vcc \pm 0.5v

These ratings are absolute maximums. Operation at or near the maximums may cause stress and eventual damage or unpredictable behaviour.

14. Designing Coils for the ID-3uP

(Note the ID-12uP and the ID-20uP must not be used with an external antenna.)

The antenna Inductance for the ID-3uP is 1.34mH. When this value is used the external tuning capacitor (C3) is not required because the ID-3uP already has an internal tuning capacitor of 1n2. In general the bigger the antenna the better it is, provided the reader is generating enough field strength to excite the tag. The ID-3uP is low power so a maximum coil size of 8x8cm is recommended if it is intended to read ISO cards. If the reader is intended to read glass tags the maximum coil size should be smaller, say 3x3cm. There is a science to determine the exact size of an antenna but there are so many variables that in general it is best to get a general idea and then 'Suck it and See'. If the reader is located in a position where there is a lot of heavy interference then less range may be unavoidable. In this situation the coil should be made smaller to increase the field strength and reduce the interference pickup. It is difficult to give actual examples of coils for hand winding because the closeness and tightness of the winding will significantly change the inductance. A professionally wound coil will have much more inductance than a similar hand wound coil.

For those who want a starting point into practical antenna winding it was found that 83 turns on a 80mm diameter former gave an inductance of 1.34mH. As far as the inductance is concerned, the wire diameter is not important, although thicker wire often means higher Q and slightly more read range.

Sometimes the antenna coil is necessarily surrounded by a metallic enclosure or has an adjacent copper PCB plane. Both these can behave like a shorted turn. A shorted turn has the effect of setting up a current in opposition to the ID-3uP antenna coil current and is analogous to adding a negative inductance. Some range can be clawed back by either increasing the inductance or increasing the capacitance. If an inductance meter that works at 100 KHz or greater is available then the inductance can be adjusted back to 1.34mH by winding extra turns

Remember, that normally there is no need for external capacitance because the ID-3uP has an internal 1n2 capacitor, which perfectly tunes the recommended inductance of 1.34mH. If the user monitors the coil voltage with an oscilloscope, this will tell all. As a tip, if ferrite is brought near a coil with too low inductance, the RF output voltage will rise and if aluminium foil is brought near a coil which has too high inductance, the RF voltage will similarly rise. This will indicate which side of the tuning the coil is.

Warning: Do not exceed the stated maximum voltages and currents for the ID-3uP RF output.

For those who wish to be more theoretical we recommend a trip to the Microchip Website where we found an application sheet for Loop Antennas. All the same, once the user has got some theoretical knowledge, the advice of most RF experts is still 'Suck it and see'. <http://ww1.microchip.com/downloads/en/AppNotes/00831b.pdf>

15. Tuning the ID-3uP (External Antenna)

For development we recommend using an oscilloscope for tuning. Use a high impedance probe on 10x for Isolation, and to protect the oscilloscope input amplifiers. Connect the oscilloscope to observe the 125kHz AC voltage across the coil. Get a sizeable piece of ferrite and bring it up to the antenna loop. If the voltage increases then more inductance is required (or more capacitance). If the voltage decreases as the ferrite is brought up to the antenna then the inductance is too great. If no ferrite is to hand then a piece of aluminium sheet may be used for testing in a slightly different way. Opposing currents will flow in the aluminium and it will act as a negative inductance. If the 125kHz AC voltage increases as the aluminium sheet approaches the antenna then the inductance is too high. Note it may be possible that the voltage will first maximize then decrease. This simply means that the antenna is near optimum tuning. If ferrite is used then the coil is a little under value and if aluminium sheet is used then the coil is a little over value. The RF driver includes protection resistors which protect the module against momentary RF shorts. The resistors also make the tuning much less critical and this is deliberate. For production a go/no-go range test is all that is required.

Note that the module RF output may be shorted momentarily to ground without damage but heat dissipation may damage the internal drivers if a short is sustained. Be careful to keep the RF pins from shorting to other module pins.

16. DC Characteristics

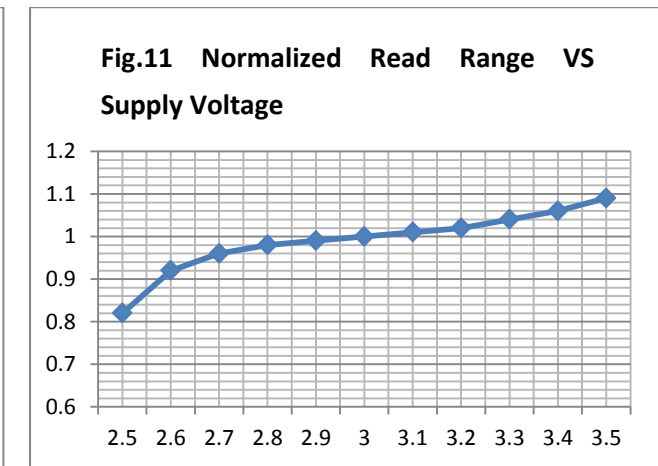
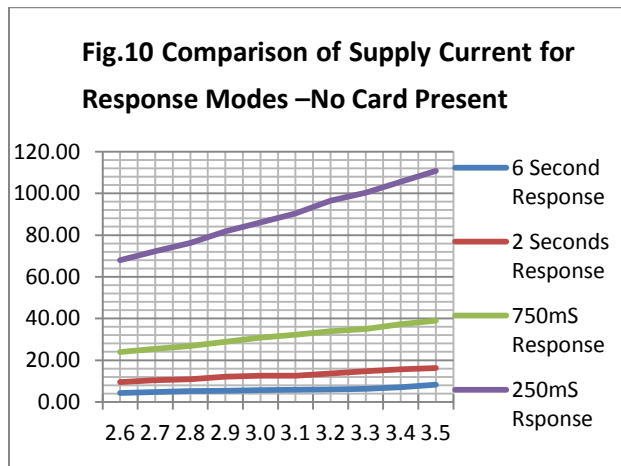
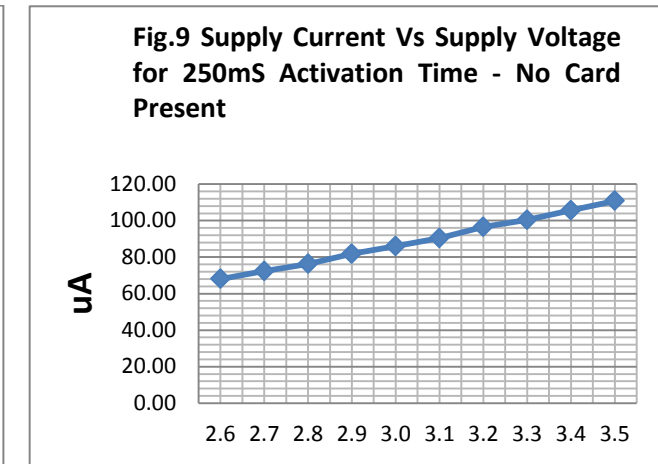
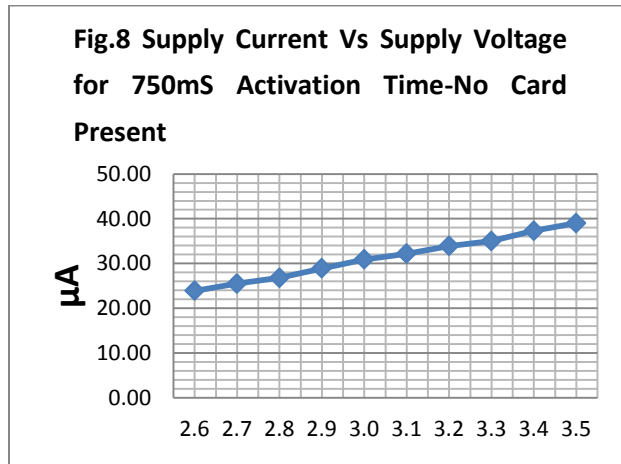
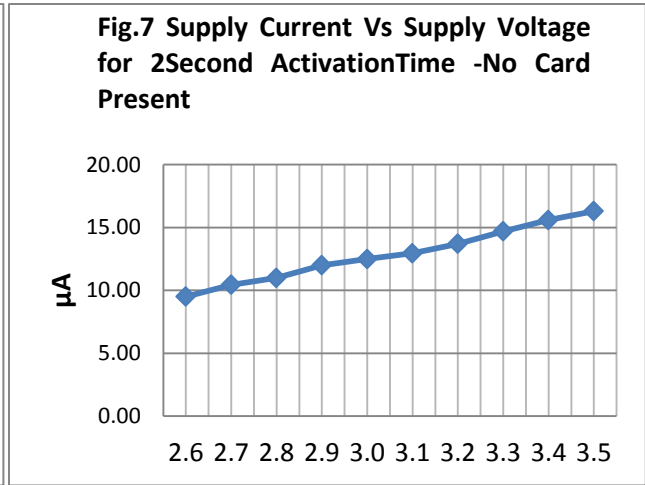
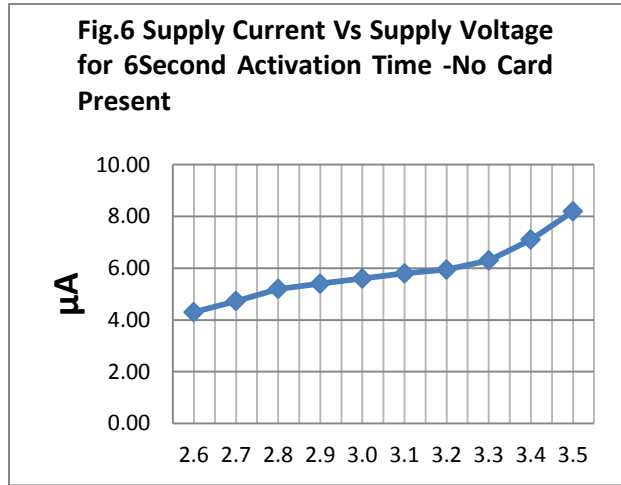

17. Useful information

The Bray++ Terminal

For general testing we suggest the user downloads a terminal program free from the internet. Here is one particularly good one to consider: <http://sites.google.com/site/terminalbpp/> Truly an excellent piece of software. If this is hard to get try a search for Bray 1.9b 20100630. This version is good but any version will be also acceptable.

Technical Queries

If you have any technical queries please contact your local distributor, they have all the technical resources to help you and support you. Where no local distributor exists, our technical helpline may be contacted by writing to help@ID-Innovations.com

Please state your geographic region, the module serial number and where you obtained it.

Q & A

Questions and answers to technical problems are available on line at ID-Innovations.Com. Customer feedback is *always* appreciated.

18. Case Dimensions for ID-xxuP

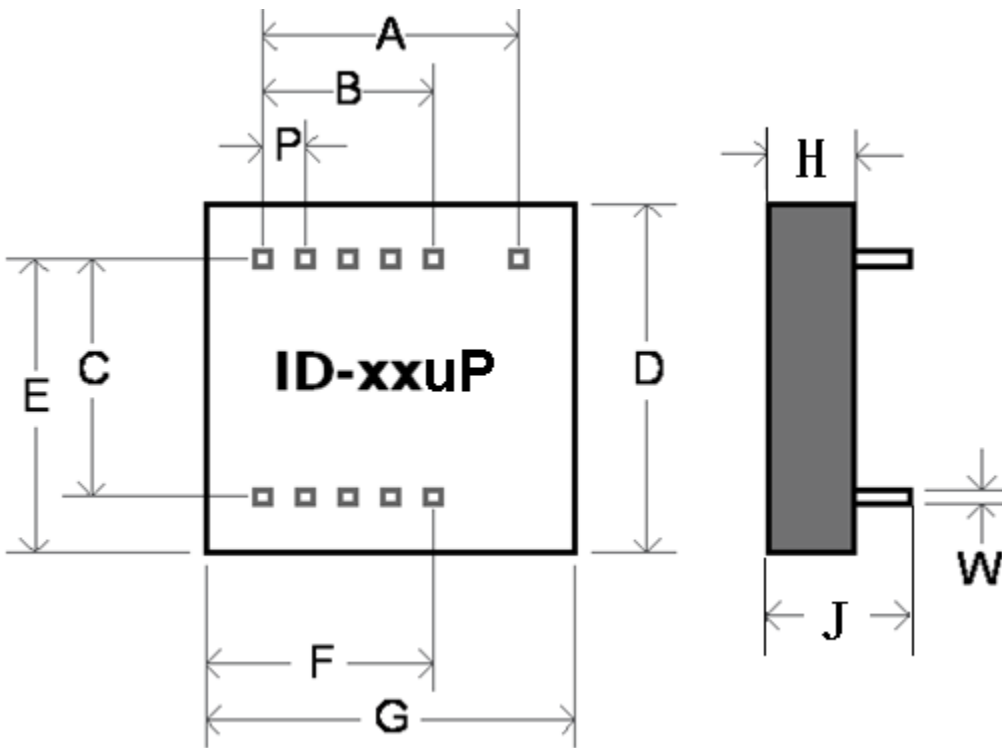

	ID-3uP			ID-12uP			ID-20uP		
	Nom	Min	Max	Nom	Min	Max	Nom	Min	Max
A	12.0	11.6	12.4	12.0	11.6	12.4	12.0	11.6	12.4
B	8.0	7.6	8.4	8.0	7.6	8.4	8.0	7.6	8.4
C	15.0	14.6	15.4	15.0	14.6	15.4	15.0	14.6	15.4
D	20.5	20.0	21.5	25.3	24.9	25.9	40.3	40.0	41.0
E	18.5	18.0	19.2	20.3	19.8	20.9	27.8	27.5	28.5
F	14.0	13.0	14.8	16.3	15.8	16.9	22.2	21.9	23.1
G	22.0	21.6	22.4	26.4	26.1	27.1	38.5	38.2	39.2
P	2.0	1.8	2.2	2.0	1.8	2.2	2.0	1.8	2.2
H	5.92	5.85	6.6	6.0	5.8	6.6	6.8	6.7	7.0
J	9.85	9.0	10.5	9.9	9.40	10.5	9.85	9.4	10.6
W	0.66	0.62	0.67	0.66	0.62	0.67	0.66	0.62	0.67

All Dimensions in mm

19. Contact Information

Head Office—Australia

ID Innovations

21 Sedges Grove

Canning Vale, W.A. 6155

Telephone: +61 8 94554615

Fax: +61 8 94553615

20. Important Safety Notice

Never use this reader in applications of sustaining life, for locks on medical cabinets or any application where power failure or reader failure can cause bodily harm, damage, injury or loss.

Disclaimer

The information in this document is provided solely for the use of ID Innovations' products. There are no express or implied copyright licenses or intellectual property rights granted to design or fabricate any of ID Innovations' products based on the information provided in this document.

ID Innovations reserves the right to make changes to specifications and product descriptions at any time without notice. The specifications provided in ID Innovations' datasheets can and do vary in different applications and actual performance may vary over time.

ID Innovations' products are not intended for and will not be used in life support systems, human implantation, nuclear facilities or systems or any other application where product failure could lead to loss of life or catastrophic property damage.

ID Innovations makes no warranty, representation or guarantee regarding the suitability of its products for any purpose, and it assumes no liability, whether claim, loss, damage or expense of any kind caused in whole or in part, directly or indirectly by the inadequacy of any products for any purpose, any infringement, deficiency or defect in any products whether or not covered by any manufacturer's warranty, the use or performance of any products, any interruption or loss of service, or any special, direct, indirect, incidental or consequential damage, including, without limitation, personal injury or loss of business or profit, or other damage, whether or not ID Innovations has been informed of the possibility or likelihood of such or any other damages, arising out of the application or use of any product and information provided.

Appendix A - ID-12uP /ID-12uP-SA Demo Board.

Details of a demo board for ID-12uP and ID-12uP-SA are given below. Users are free to copy, use or modify all or part of the board for their own purposes. No guarantees are given as to the suitability of the board for any purpose. The board is provided only to allow customers to evaluate the ID-12uP and ID-12uP-SA. The ID-12uP-SA is also has the ability to store 35 cards and operate a Strike logic. LED2 and Q2 are only associated with the ID-12-uP-SA module only.

Demo Board PCB Top Layer

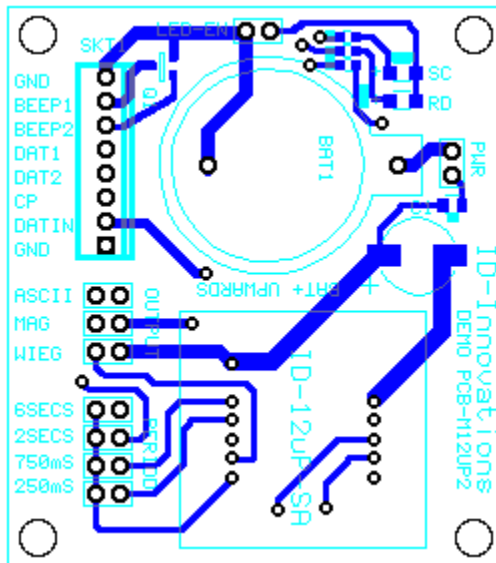

Demo Board Bottom Layer

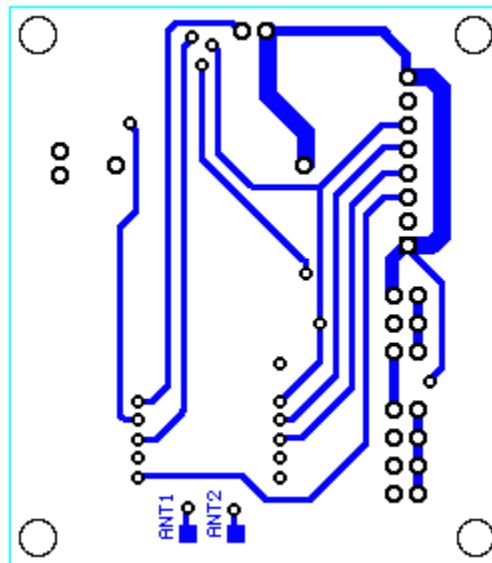

Part	Description
Module	ID-12uP
Bat1	C2023 Lithium 3v
Led1	1206 SMD LED
Led2	1206 SMD LED
Led3	1206 SMD LED
R1	0805 10R
R2,R3,R4	0603 5k6
LK1-LK8	0.1" Pitch Links
C1	RUBYCON TZV 1000/6.3
Q1,Q2	ZXMS6004 FCCT-ND

Demo Board Schematic

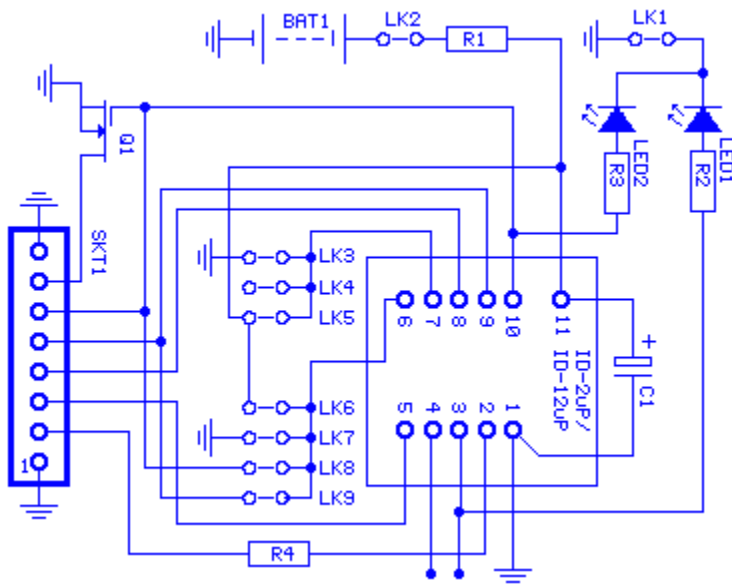

Q1 and Q2 are ‘Smart’ FETs and resistant to current overload and dissipate damage. Other logic-level CMOS FETs may be used. R1 can in practice be anything from 10-100 ohm. It is just a protection resistor for experimental purposes. C1 can be any-value from 1uF-100uF, although slightly better performance will be obtained with higher values. Gerber files may be downloaded from our website.