

MDL-2001

Laser Scan Engine

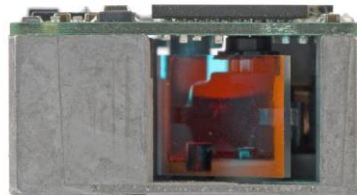

Specification Manual – Rev 3.0

All information subject to change without notice.

Document History

Model Number:	MDL-2001	Specification Number:	SS09033
Edition:	3rd	Original Spec Number:	SS08040
Date:	2024-07-26		

Copyright 2024 Opticon. All rights reserved.

This manual may not, in whole or in part, be copied, photocopied, reproduced, translated or converted to any electronic or machine readable form without prior written consent of Opticon.

Limited Warranty and Disclaimers

PLEASE READ this manual CAREFULLY before installing or using the product.

Serial Number

A serial number appears on all Opticon products. This official registration number is directly related to the device purchased. Do not remove the serial number from your Opticon device. Removing the serial number voids the warranty.

Warranty

Unless otherwise agreed in a written contract, all Opticon products are warranted against defects in materials and workmanship for two years after purchase. Opticon will repair or, at its option, replace products that are defective in materials or workmanship with proper use during the warranty period. Opticon is not liable for damages caused by modifications made by a customer. In such cases, standard repair charges will apply. If a product is returned under warranty and no defect is found, standard repair charges will apply. Opticon assumes no liability for any direct, indirect, consequential or incidental damages arising out of use or inability to use both the hardware and software, even if Opticon has been informed about the possibility of such damages.

Packaging

The packing materials are recyclable. We recommend that you save all packing material to use should you need to transport your scanner or send it for service. Damage caused by improper packaging during shipment is not covered by the warranty.

Trademarks

Trademarks used are the property of their respective owners.

Opticon Inc. and Opticon Sensors Europe B.V. are wholly owned subsidiaries of OPTOELECTRONICS Co., Ltd., 12-17, Tsukagoshi 4-chome, Warabi-shi, Saitama, Japan 335-0002. TEL +81-(0) 48-446-1183; FAX +81-(0) 48-446-1184

Support

USA

Phone: 800-636-0090

Email: support@opticon.com

Web: www.opticonusa.com

Rest of World

Phone: +31235692728

Email: support@opticon.com

Web: www.opticon.com

Contents

1	Abstract	5
2	Overview	5
3	Physical Features	5
3.1	Dimensions	5
3.2	Weight.....	5
4	Environmental Specifications	6
4.1	Operating Temperature and Humidity	6
4.2	Storage Temperature and Humidity	6
4.3	Ambient Light Immunity	6
5	Electrical Specifications	7
5.1	Absolute Maximum Ratings.....	7
5.2	Electrical Characteristics	7
5.3	Power Mode Transition.....	8
6	Optical Specifications	9
6.1	Laser Scanning.....	9
6.2	Laser Line Specifications.....	9
6.2.1	Tilt of Scan Line	9
6.2.2	Curvature of Scan Line	9
7	Technical Specifications	10
7.1	Print Contrast Signal (PCS).....	10
7.2	Scan Area and Depth of Field	11
7.3	Pitch, Skew, and Tilt	12
7.4	Curvature	13
8	Interface Specifications	14
8.1	Interface Connector	14
8.2	Interface Circuit.....	14
9	Serial Number	16
10	Packaging Specifications	17
11	Durability	18
11.1	Electrical Noise.....	18
11.2	Shock	18
11.3	Vibration Strength.....	18
12	Reliability	19
13	Regulatory Compliance	19
13.1	Laser Safety	19
13.2	RoHS.....	19
14	Safety	20
14.1	General use.....	20
14.2	Shock	20

14.3	Temperature & Environment	20
14.4	Anti-static Treatments	20
14.5	Foreign materials & Cleaning	20
15	Precautions.....	21
15.1	Laser Light Safety Precautions	21
15.2	Handling	21
16	Mechanical Drawing.....	22

Table of Figures

Figure 1: Current waveform	8
Figure 2: Power mode transition.....	8
Figure 3: Laser line specifications	9
Figure 4: Scan area and depth of field	11
Figure 5: Pitch, skew, and tilt.....	12
Figure 6: Curvature.....	13
Figure 7: Serial number diagram	16
Figure 8: Packaging.....	17
Figure 9: Mechanical drawing.....	22

1 Abstract

This manual provides specifications for the MDL 2001 laser scan engine.

2 Overview

The MDL 2001 laser scan engine is a compact laser barcode scan engine that can be installed in various handheld products, such as a mobile computer. The MDL2001 is able to scan and decode a wide variety of barcodes at close range, as well as at a relatively large distance. The use of a short-wavelength red laser beam enhances visibility of the laser line.

A decoder is built into the MDL 2001 that allows this scan engine to decode barcodes after scanning and to output the information using serial communication.

The MDL 2001 complies with the Restriction of Hazardous Substances (RoHS).

3 Physical Features

3.1 Dimensions

W 20.4 x D 18.0 x H 11.2 mm

3.2 Weight

4.7 g (max.)

4 Environmental Specifications

4.1 Operating Temperature and Humidity

Temperature	: -20 ~ 65° C
Humidity	: 5 ~ 90% RH

4.2 Storage Temperature and Humidity

Temperature	: -30 ~ 70° C
Humidity	: 5 ~ 90% RH

4.3 Ambient Light Immunity

Decoding performance is guaranteed when the range of illumination on a barcode surface is between zero and the following values:

Incandescent light	4,000 lx
Fluorescent light	4,000 lx (excluding high-frequency lighting)
Sunlight	80,000 lx

Conditions:

Barcode	OPTOELECTRONICS Test Sample
PCS:	0.9
Resolution:	0.25 mm
Symbology:	9-digit Code 39
Quiet zone:	10 mm
N/W ratio:	1:2.5
Distance:	150 mm
Angle (see note below):	$\alpha = 0^\circ \beta = 15^\circ \gamma = 0^\circ$
Curvature:	$R = \infty$
Power supply voltage:	3.3 V

Avoid specular (mirror like) reflection from the laser line..

Note: α , β and γ respectively represent pitch, skew and tilt. Refer to section 6.2 for details on those parameters.

5 Electrical Specifications

5.1 Absolute Maximum Ratings

Parameter	Symbol	Value	Unit
Power supply voltage (V _{CC} to GND)	V _{CC}	3.9	V
Input voltage	V _{IN}	-0.3 ~ V _{CC} +0.3	V

5.2 Electrical Characteristics

Electrical characteristics: V_{CC}=3.3 V, Ta=25° C

Item	Symbol	Conditions	Min	Typ	Max	Unit
Operating Voltage	V _{CC}		3.0	—	3.6	V
Operating Current 1	I _{OP1}	READ State	—	110	125	mA
Operating Current 2	I _{OP2}	READ State		95	110	mA
Idle Current	I _{IDL}	IDLE State	—	30	40	mA
Aiming Current	I _{AIM}	AIMING State	—	50	65	mA
Low Power Current	I _{LOW}	Low Power State	—	—	1400	uA
Rush Current Peak	I _{PEEK}		—	500	1000	mA
Input Voltage	High	V _{IH}	V _{CC} x 0.8	—	—	V
	Low	V _{IL}	—	—	V _{CC} x 0.2	V
Output Voltage (Decode LED)	High	V _{OH}	I _{OH} < 8 mA	V _{CC} -0.6	—	V
	High (Low Power State)	V _{OH}	I _{OH} < 5 uA	V _{CC} -0.6	—	V
	Low	V _{OL}	I _{OL} < 8 mA	—	—	0.4
Output Voltage (Txd, RTS)	High	V _{OH}	I _{OH} < 4 mA	V _{CC} -0.6	—	V
	High (Low Power State)	V _{OH}	I _{OH} < 5 uA	V _{CC} -0.6	—	V
	Low	V _{OL}	I _y < 4 mA	—	—	0.4
Output Voltage (Power Down)	High (Low Power State)	V _{OH}	I _{OH} < 5 uA	V _{CC} - 0.6	—	V
	Low	V _{OL}	I _{OL} < 4 mA	—	—	0.4
Input Current	I _{IN}	V _{IN} =3.3 V	—	—	50	μA
		V _{IN} =0 V	—	—	-10	μA

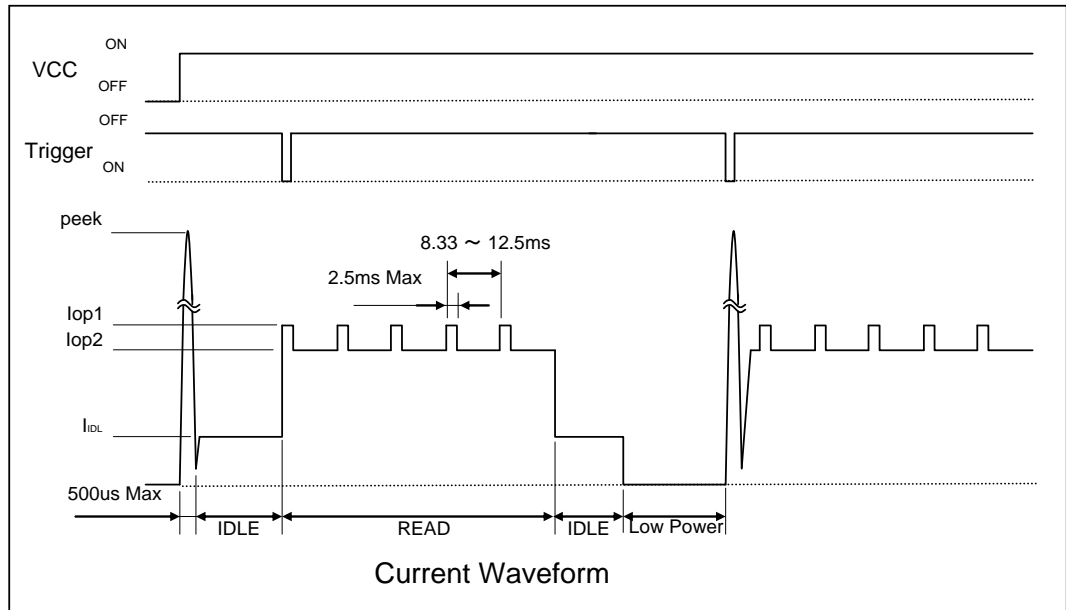

Figure 1: Current waveform

5.3 Power Mode Transition

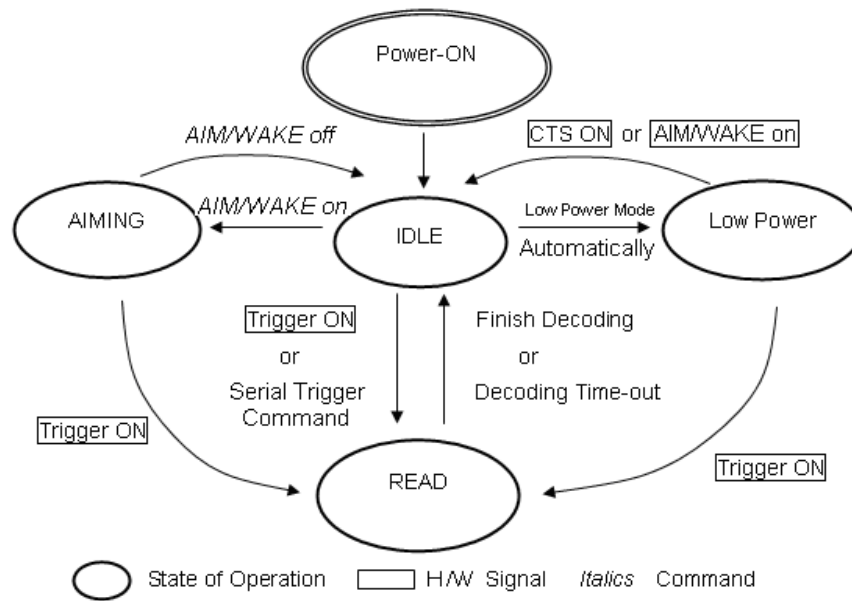

Figure 2: Power mode transition

- When this scan engine is configured for low power mode, the operating state automatically changes from “IDLE” to “Low Power” state.
- If there is a transition from “Low Power” to “IDLE” as a result of “CTS ON” or “WAKE ON” the operating mode will automatically go back to “Low Power” in one second unless some signal causes a transition to another state.

6 Optical Specifications

6.1 Laser Scanning

Parameter	Specification	Unit
Light-emitting element	Red laser diode	-
Emission wavelength	650 ±10 (25° C)	nm
Light output	1.0 or less	mW
Scanning method	Bi-directional scanning	-
Scanning speed	100 ±20	scans/s
Scan angle	Scan angle: 54 ±5	degrees
	Read angle: 44 (Min)	degrees

6.2 Laser Line Specifications

6.2.1 Tilt of Scan Line

The angle between the average center of the scan line and the horizontal line:

0.92° or less

(Maximum 2.46 mm when measured at 150 mm from the scan origin.

The measurement shall be done at the center of the scan line).

6.2.2 Curvature of Scan Line

The angle between the line connecting the scan origin (the moving mirror) and the average center of the scan line and the line connecting the scan origin and the maximum top of the scan line.

1.17° or less (Maximum of 3.06 mm measured at 150 mm from the scan origin.

The measurement shall be done at the center of the scan line.)

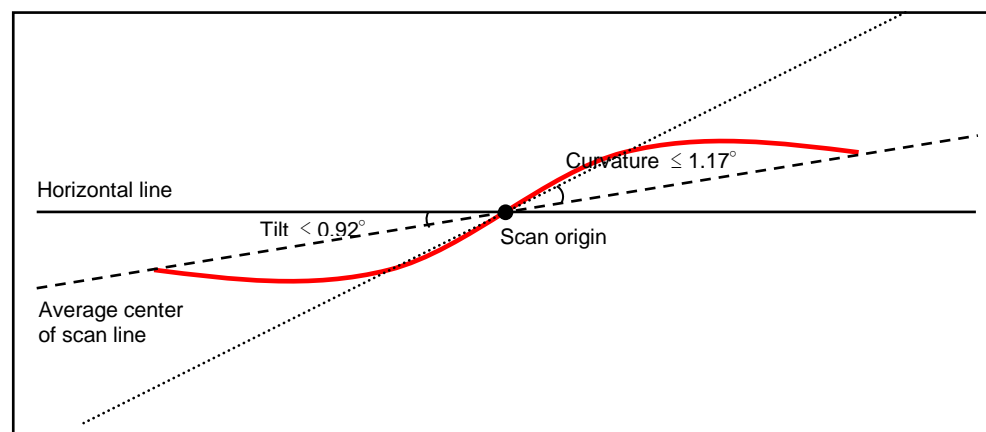

Figure 3: Laser line specifications

7 Technical Specifications

The conditions for the technical specifications are as follows, unless otherwise specified in each section.

Conditions:

Ambient temperature and humidity	Room temperature and room humidity
Ambient light	500 ~ 900 lx (excluding high-frequency lighting)
Background of barcode	Black
Power supply voltage	3.3 V
Decoding test	Approve the performance when decoding is successful in all ten tests. (Decoding is deemed successful when completed in 0.5 seconds or less.)

7.1 Print Contrast Signal (PCS)

0.45 or higher (over 70% of reflectivity of space and quiet zone).

$$PCS = \frac{\text{Reflectance of white bar} - \text{Reflectance of black bar}}{\text{Reflectance of white bar}}$$

Scanning performance may decline if dirt or scratches mark the optical window. Keep the optical window clean.

7.2 Scan Area and Depth of Field

The depth of the decoding field is measured from the front edge of the scan engine.

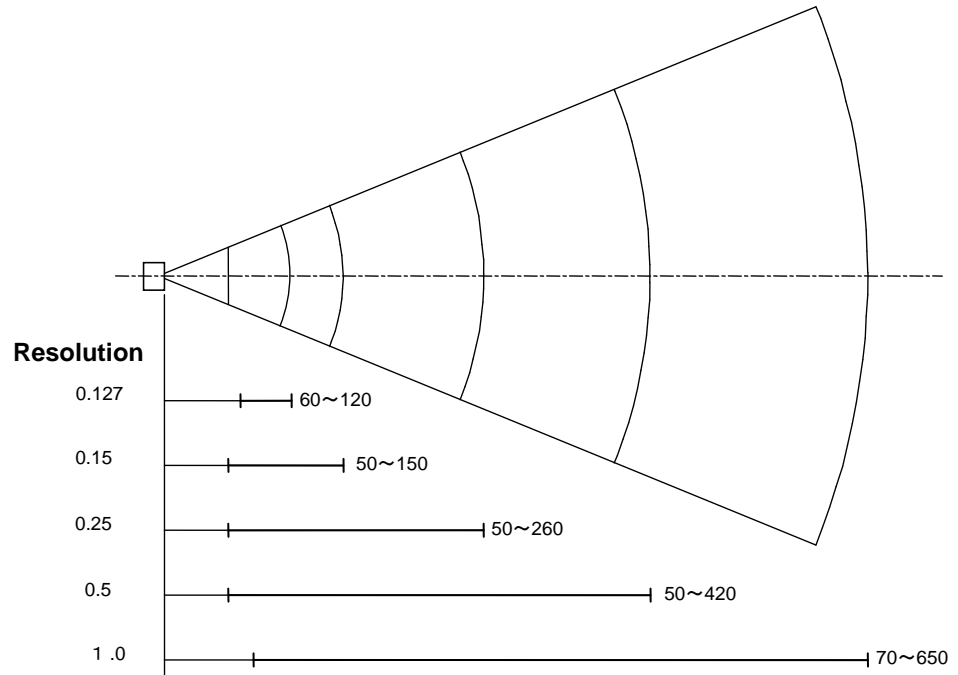

Figure 4: Scan area and depth of field

(Unit: mm)

Conditions:

Resolution	Symbology	PCS	Quiet Zone	Digits
1.0 mm	Code 39	0.9	25 mm	1
0.5 mm	Code 39	0.9	18 mm	3
0.25 mm	Code 39	0.9	10 mm	8
0.15 mm	Code 39	0.9	7 mm	10
0.127 mm	Code 39	0.9	5 mm	4

Barcode OPTOELECTRONICS Test Sample

N/W Ratio 1:2.5

Angle $\alpha = 0^\circ, \beta = 15^\circ, \gamma = 0^\circ$

Curvature $R = \infty$

7.3 Pitch, Skew, and Tilt

Pitch angle : $\alpha \leq \pm 35^\circ$

Skew angle : $\beta \leq \pm 50^\circ$ (Excluding dead zone)

Dead zone : $\beta \leq \pm 8^\circ$ (There are some areas where decoding fails due to specular reflection)

Tilt Angle : $\gamma \leq \pm 20^\circ$

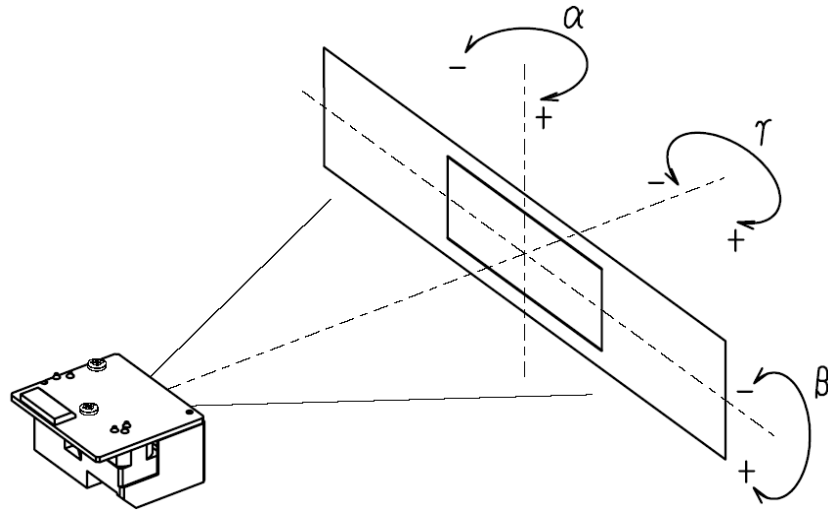

Figure 5: Pitch, skew, and tilt

Conditions:

Barcode	OPTOELECTRONICS Test Sample
Distance	110 mm from the front edge of the scan engine.
Label	<p>Pitch, Skew Angle, Dead Zone PCS = 0.9, Resolution = 0.25 mm, Symbology = 9-digit Code 39, Quiet Zone = 10 mm, N/W Ratio = 1:2.5</p> <p>Tilt Angle PCS = 0.9, Resolution = 0.26 mm, Symbology = 13-digit JAN, Quiet Zone = 10 mm</p>
Angle	Curvature: $R = \infty$, Skew Angle = $\beta + 15^\circ$ (for measuring Pitch Angle and Tilt Angle)

7.4 Curvature

8-digit UPC/EAN	$R \geq 15$ mm.
13-digit UPC/EAN	$R \geq 20$ mm.

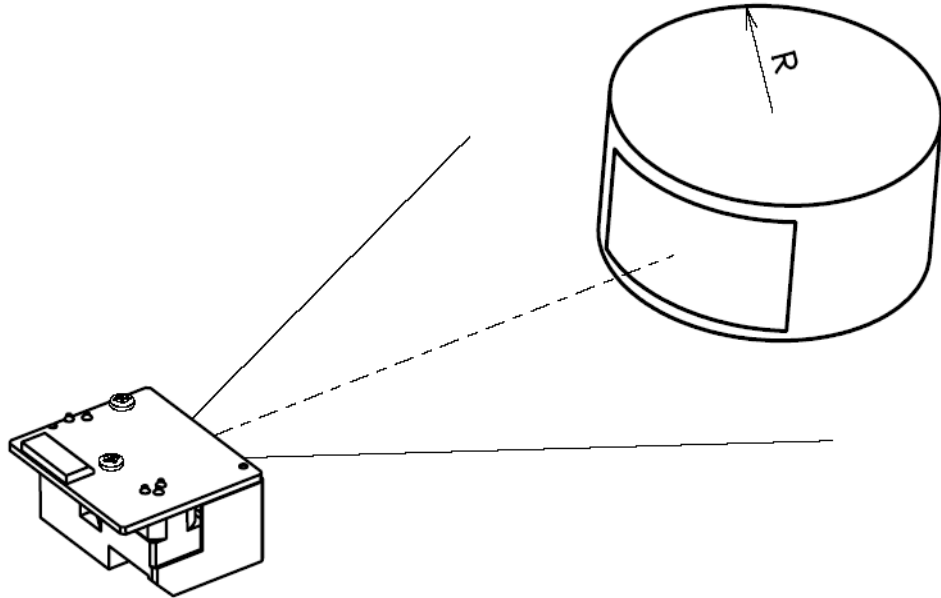

Figure 6: Curvature

Conditions:

Barcode	OPTOELECTRONICS Test Sample PCS = 0.9, Resolution = 0.26 mm, Quiet Zone = 10 mm
Distance	110 mm from the front edge of the scan engine
Angle	Skew Angle $\beta = +15^\circ$

8 Interface Specifications

8.1 Interface Connector

Signal	Pin No.	I/O	Features
TEST	1	I	High or Open = Normal Operation, Low = Maintenance Mode *
VCC	2	—	Power Supply: DC 3.0 V to 3.6 V
GND	3	—	Ground
Rxd	4	I	Input Serial Data, CMOS Logic Level
Txd	5	O	Output Serial Data, CMOS Logic Level
CTS	6	I	Clear to Send, CMOS Logic Level
RTS	7	O	Request to Send, CMOS Logic Level
Power Down	8	O	Power Down Output, CMOS Logic Level High = Low Power State
Buzzer	9	O	Buzzer Control Pulse Output, CMOS Logic Level Low = Buzzer On
Decode LED	10	O	LED Output, CMOS Logic Level Low = LED On
Aim/Wake	11	I	Aiming / Wakeup Input, CMOS Logic Level Low =
Trigger	12	I	Trigger Input, CMOS Logic Level Low =

Connector used was produced by KYOCERA ELCO Corporation.
Product No. 04 6238 012 0 1 0 800+

12 pin 0.5 mm pitch FFC Connector Bottom contact (Tinned terminal)

8.2 Interface Circuit

Pin No.	Signal	Circuitry
1	<p>Test Terminal High = Normal Operation Mode Low = Maintenance Mode</p>	
2	VCC	—
3	GND	—
4	Rxd Input	

Pin No.	Signal	Circuitry
5	Txd Output	
6	CTS Input	
7	RTS Output	
8	Power Down Output High = Low Power State	
9	Buzzer Output High = OFF Low = ON	
10	Decode LED Output High = OFF Low = ON	
11	Aim/Wake Input Low = Aim / Wake	

Pin No.	Signal	Circuitry
12	<p>Trigger Input Low = Trigger</p>	

9 Serial Number

The serial number label shown below is affixed to the MDL 2001.

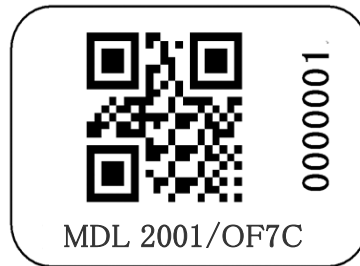

Figure 7: Serial number diagram

Management Quick Response Code (QR Code), model name, and serial number are displayed.

The serial numbers start from 0000001 and are in order regardless of the lot number.

10 Packaging Specifications

Size of the package after assembly: W 355 x D 290 x H 185 mm

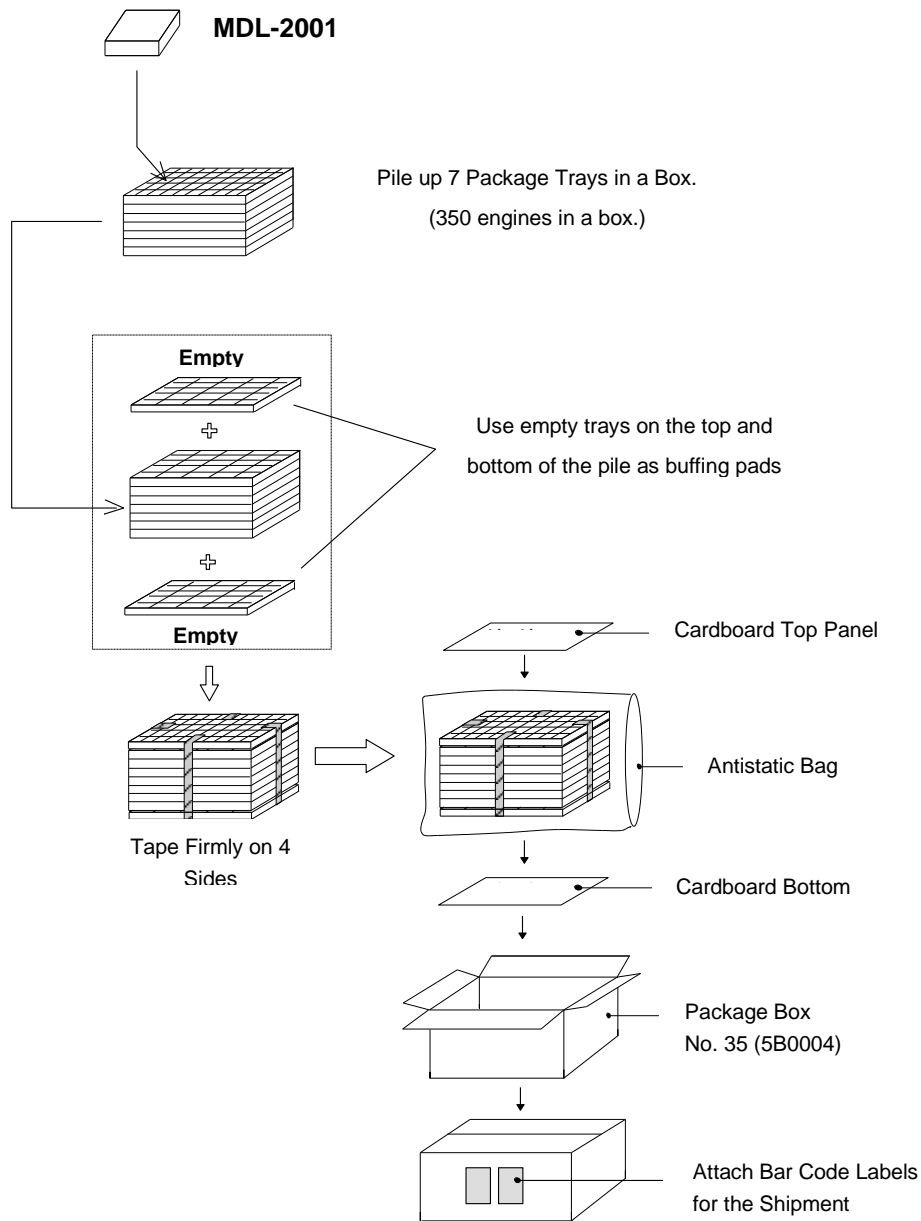

Figure 8: Packaging

Note: The “RO” mark labeled on the package tray or package box guarantees that the applicable product has passed our test of RoHS restrictions compliance (the restriction of the use of certain hazardous substances in electrical and electronic equipment, 2011/65/EU). However, this document does not have any legal weight in the European Union.

11 Durability

11.1 Electrical Noise

No malfunction occurred when sinusoidal electrical noise (50 Hz -100 kHz, < 0.1Vp-p) was added to a power supply line.

Conditions:

Barcode	OPTOELECTRONICS Test Sample
PCS	0.9
Resolution	0.25 mm
Symbology	9-digit Code 39
Quiet Zone	10 mm
N/W Ratio	1:2.5
Distance	150 mm from the front edge of the scan engine
Angle	$\alpha = 0^\circ \beta = 15^\circ \gamma = 0^\circ$
Curvature	$R = \infty$
Power Supply Voltage	3.3 V

11.2 Shock

No malfunction occurred after the following drop test.

Drop Test: Fixed an MDL 2001 inside a dummy case and dropped it on its top, bottom, front, back, left, right, top-left, top-right, bottom-left and bottom-right sides from 1.8 meters above a concrete floor. Repeated this routine ten times

11.3 Vibration Strength

No malfunction occurred after the following vibration test.

Vibration test: Increase the frequency of the vibration from 12 Hz to 200 Hz with accelerated velocity 32.3 m/s^2 (3.3 G) for over 10 minutes. Repeated this routine for 2 hours to X direction, 2 hours to Y direction, and 4 hours to Z direction.

12 Reliability

MTBF (Mean Time Between Failures)	30,000 hours (excluding the laser diode and the mirror scan unit)
Life cycle of laser diode	10,000 hours
Life cycle of mirror scan unit	10,000 hours

* Those are calculated based on standard operation of the product within the recommended temperature range and without extreme electronic or mechanical shock.

13 Regulatory Compliance

13.1 Laser Safety

JIS C6802:2011: Laser Class 2. In accordance with IEC 60825-1:2007 (2nd Edition) Class 2 (Check the warning sign on the device that has this engine installed for the publication date).

FDA CDRH Laser class II. Complies with 21 CFR 1040.10 and 1040.11 except for deviations pursuant to Laser Notice No. 50, dated June 24, 2007.

13.2 RoHS

RoHS: The restriction of the use of certain hazardous substances in electrical and electronic equipment, 2011/65/EU.

14 Safety

Handle this product carefully. Do not deliberately subject it to any of the following.

14.1 General use

Do not attempt to disassemble, modify or update this device. In case of serious malfunction, consult your local dealer or Opticon.

Do not use the scanner while operating machinery.

14.2 Shock

Do not drop or put heavy items on this product or its cable

14.3 Temperature & Environment

Do not use the scan engine at temperatures outside the specified range

- Do not use or leave this device: In areas exposed to direct sunlight for long periods of time.
- Near heat sources such as radiators, heat registers, stoves, or other types of devices that produce heat.
- Near microwaves, medical devices, or RF-emitting devices
- In the reach of blinking lights such as CRT
- During a lightning storm
- In any other areas where serious damage may occur!

14.4 Anti-static Treatments

All work-benches, tools, measuring instruments and human body parts that might contact the product must undergo preliminary anti-static measurements.

Do not touch optical or electrical components. Hold the product on its metal case when necessary.

14.5 Foreign materials & Cleaning

Do not use the product in dusty environments. In case dust gets into the product gently blow the dust off with dry air. High pressure is not allowed. Also direct contact of swabs is not allowed as it can cause deterioration of the performance.

Avoid exposure to chemicals.

Prevent contact with water or other liquids, and do not expose this engine to extremely high humidity.

15 Precautions

15.1 Laser Light Safety Precautions

Caution – the use of controls, or adjustments or performance of procedures other than those specified herein may result in hazardous radiation exposure.

Caution - Do not stare into the laser beam directly. It may harm your eyes.
Do not point the laser directly at others' eyes. It may harm their eyes.
Do not view the laser beam directly with optical instruments. It may harm your eyes.

15.2 Handling

- All work-benches, tools, measuring instruments and any part of the human body which have come into contact with MDL-2001 must undergo preliminary antistatic treatment.
- Do not touch the optical and electrical components. Hold it on the metal chassis when you carry the device.
 - Avoid handling MDL-2001 in a dusty area. In case dust gets on this product, gently blow off the dust with dry air. Direct contact of swabs and such on its optical part may cause deterioration of its performance.
- Do not drop the MDL-2001.

16 Mechanical Drawing

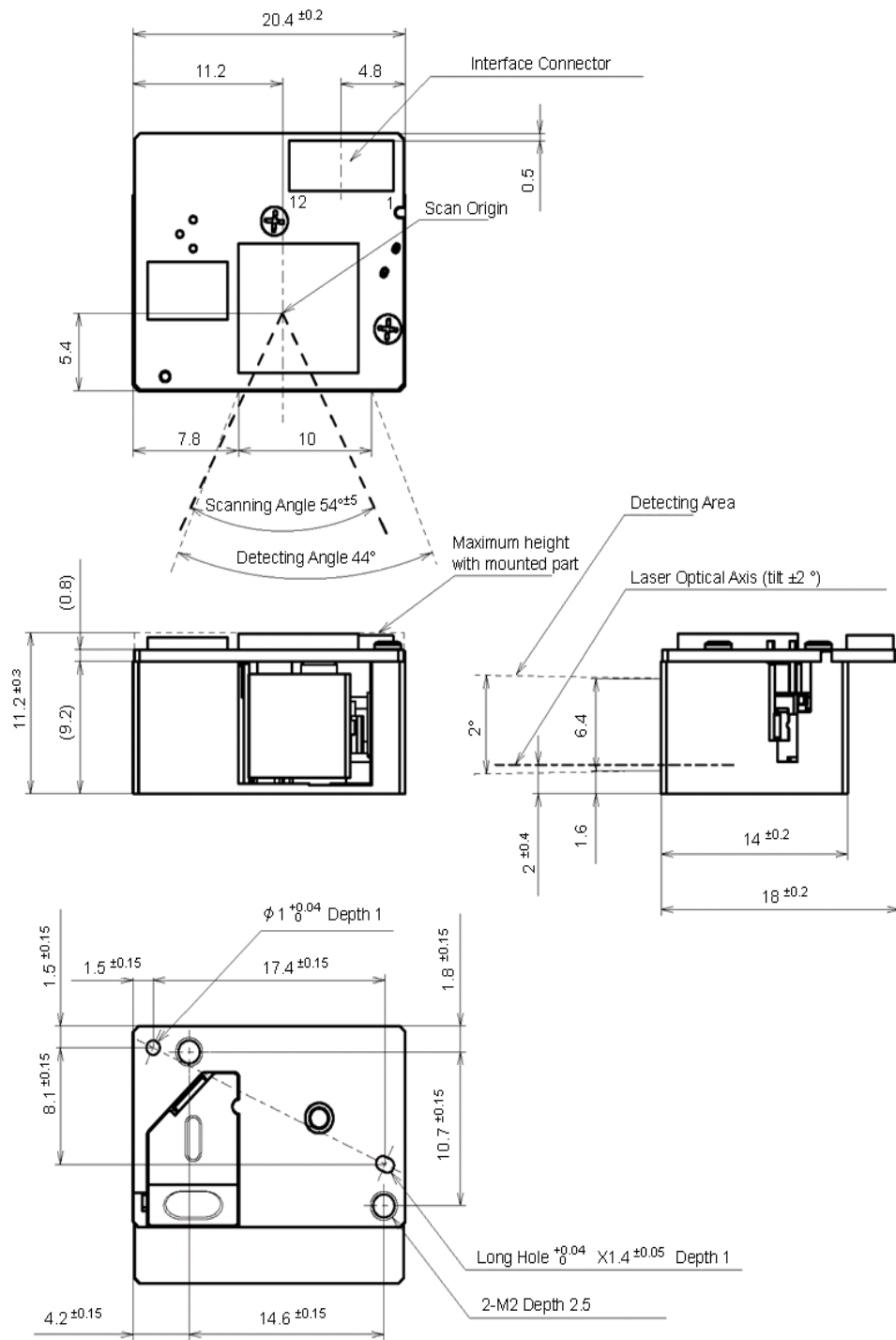

Figure 9: Mechanical drawing