

EXTRUSION

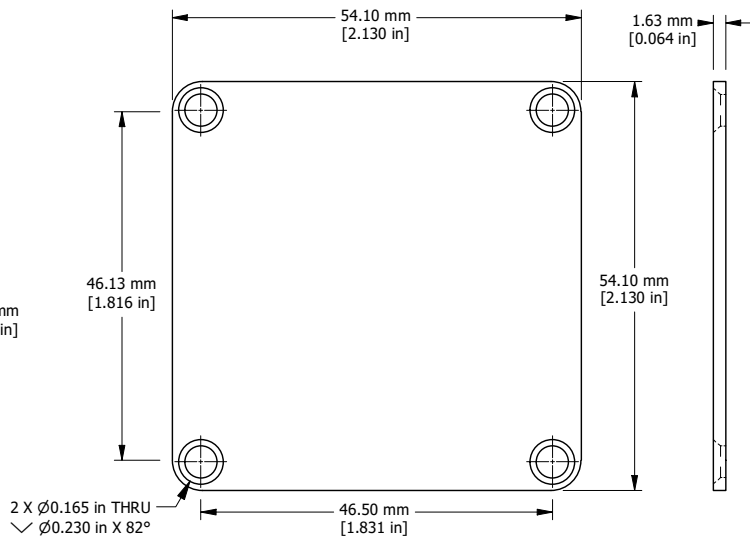

END PLATE

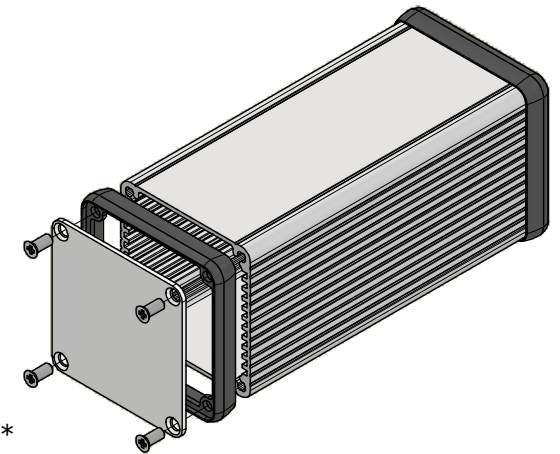

ISOMETRIC VIEW

****EXTRUSION DESIGN FOR 50MM WIDE PC BOARD****

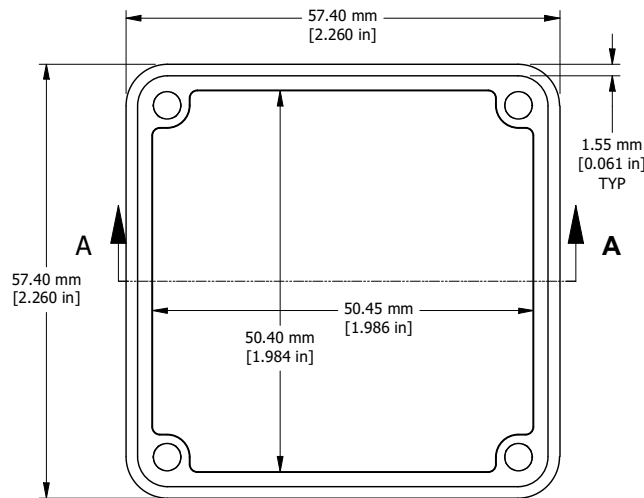
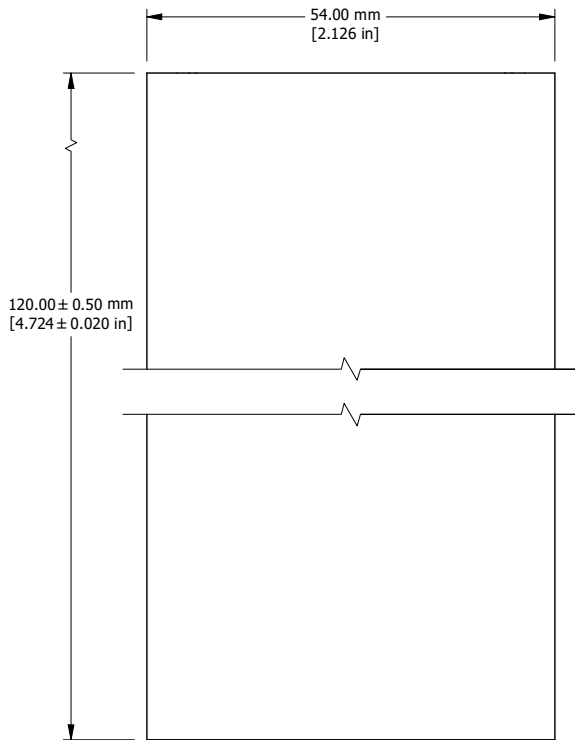

OPEN BEZEL

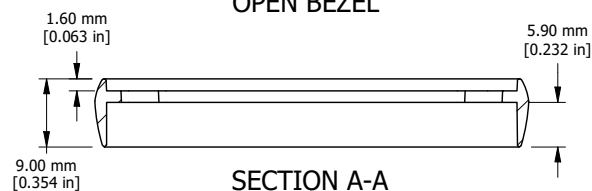

SECTION A-A

Enclosures can be Factory Modified (Milling, Drilling, Printing etc.)
 Solid models of this enclosure available in STEP or IGES.
 Contact Factory mjm@hammondmfg.com

NOTE	
Purchased assembly includes box, plastic bezels, end panels, #6 Taptight screws and self adhesive rubber feet.	
Box made from Extruded Aluminum 6063.	
Bezels made with ABS	
1455CS1201	
PART NUMBERS	
Clear Anodized	1455CS1201
Black Anodized	1455CS1201BK
ACCESSORIES	
See website for accessories.	

HAMMOND MANUFACTURING™
1455CS1201
www.hammondmfg.com