

REVISIONS					
P	LTN	DESCRIPTION	DATE	DWN	APVD
AP4		REVISED PER ECR-17-008392	28JUN2017	BW	KR
AR		REVISED PER ECR-24-218682	09SEP2024	AK	BR
AS		REVISED PER ECR-24-224423	25OCT2024	AK	BR

- MATES WITH APPROPRIATE UNIVERSAL MATE-N-LOK™ CAP OR HEADER.
- SMALL NICKS ARE PERMITTED ON THE CIRCUIT TOWERS WHICH COULD INCREASE THE INITIAL HOUSING MATING FORCE BY UP TO 4.4 NEWTONS (1.0 LBS). NO INDIVIDUAL NICKED TOWER SHALL INCREASE THIS FORCE BY OVER 2.2 NEWTONS (.5 LBS).
- DIMENSIONS SHOWN REPRESENT PRODUCT IN DRY, AS MOLDED, CONDITION. ADDITIONAL 2% GROWTH DUE TO SUBSEQUENT MOISTURE ABSORPTION MAY OCCUR AND SHOULD BE ACCOUNTED FOR.
- FOUR RIBS EQUALLY SPACED, NO SPECIFIC ORIENTATION. NO RIBS OR SIX RIBS EQUALLY SPACED, NO SPECIFIC ORIENTATION, OPTIONAL.
- UNDERWRITERS RECOGNIZED COMPONENT LOGO AND CSA CERTIFICATION LOGO TO BE LOCATED ONCE EACH ON SIDE OF HOUSING.
- MANUFACTURING LOCATION ID ON SIDE OF HOUSING (OPTIONAL).
- TRADEMARK LOCATION (AMP OR TE CONNECTIVITY).
- OBsolete PARTS: OBSOLETE CIS STREAMLINING PER D.RENAUD/D.SINISI

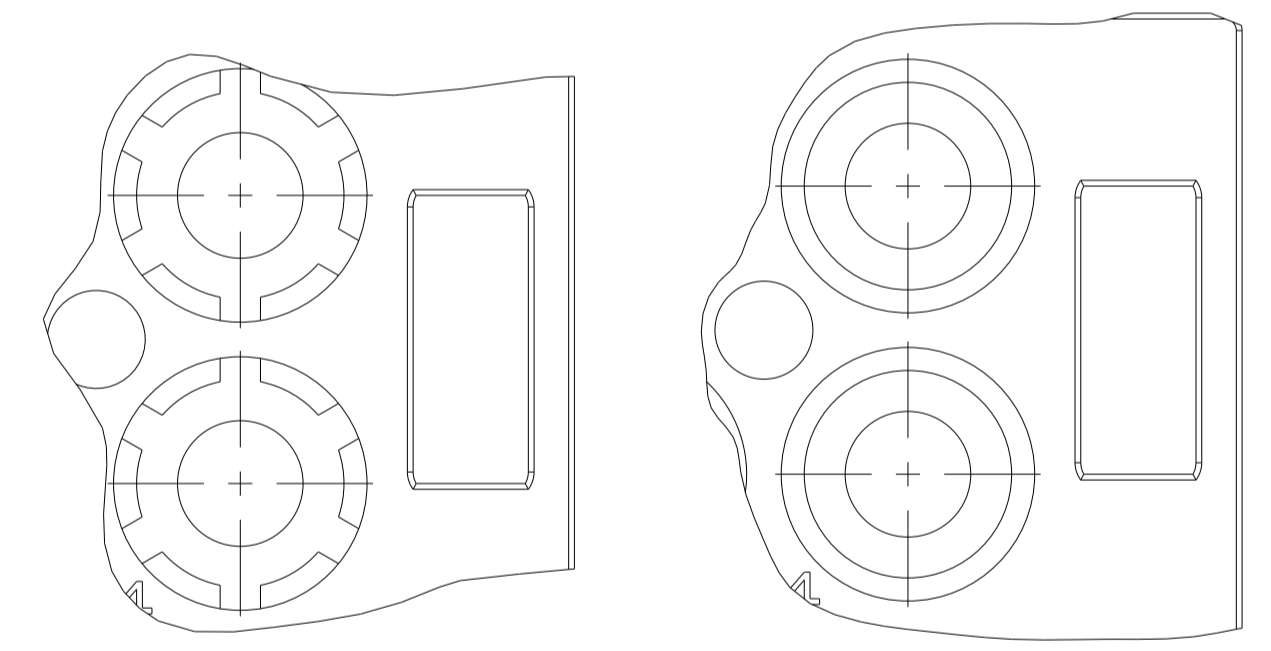

DETAIL A
SCALE 6:1
OPTIONAL CONSTRUCTION

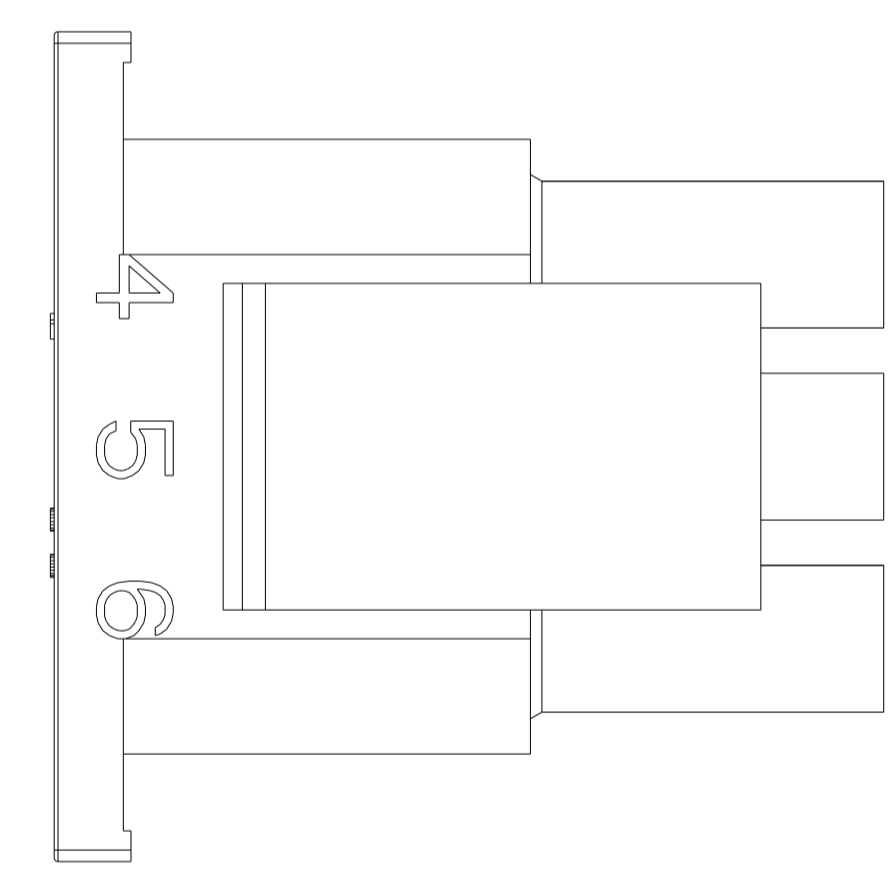
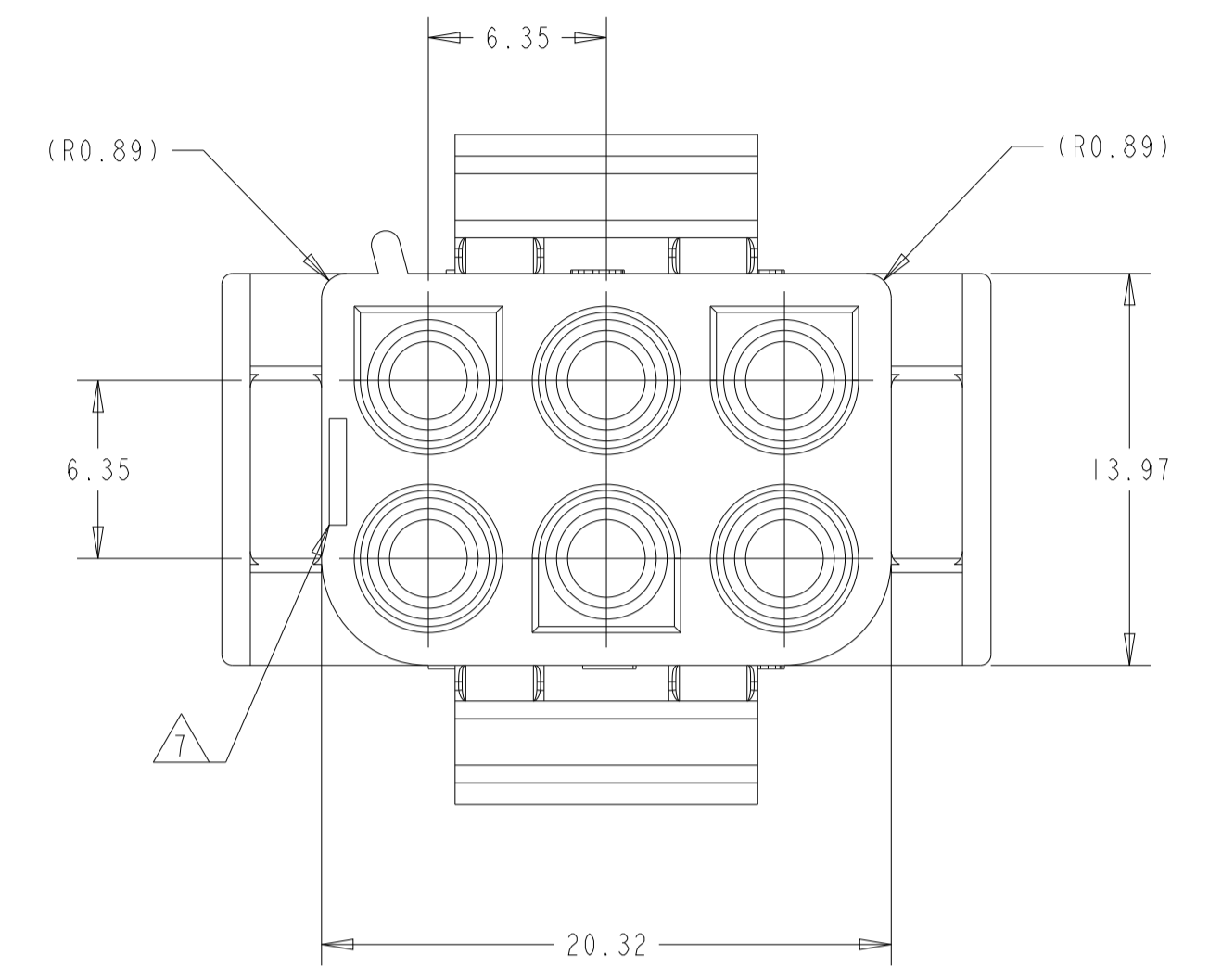
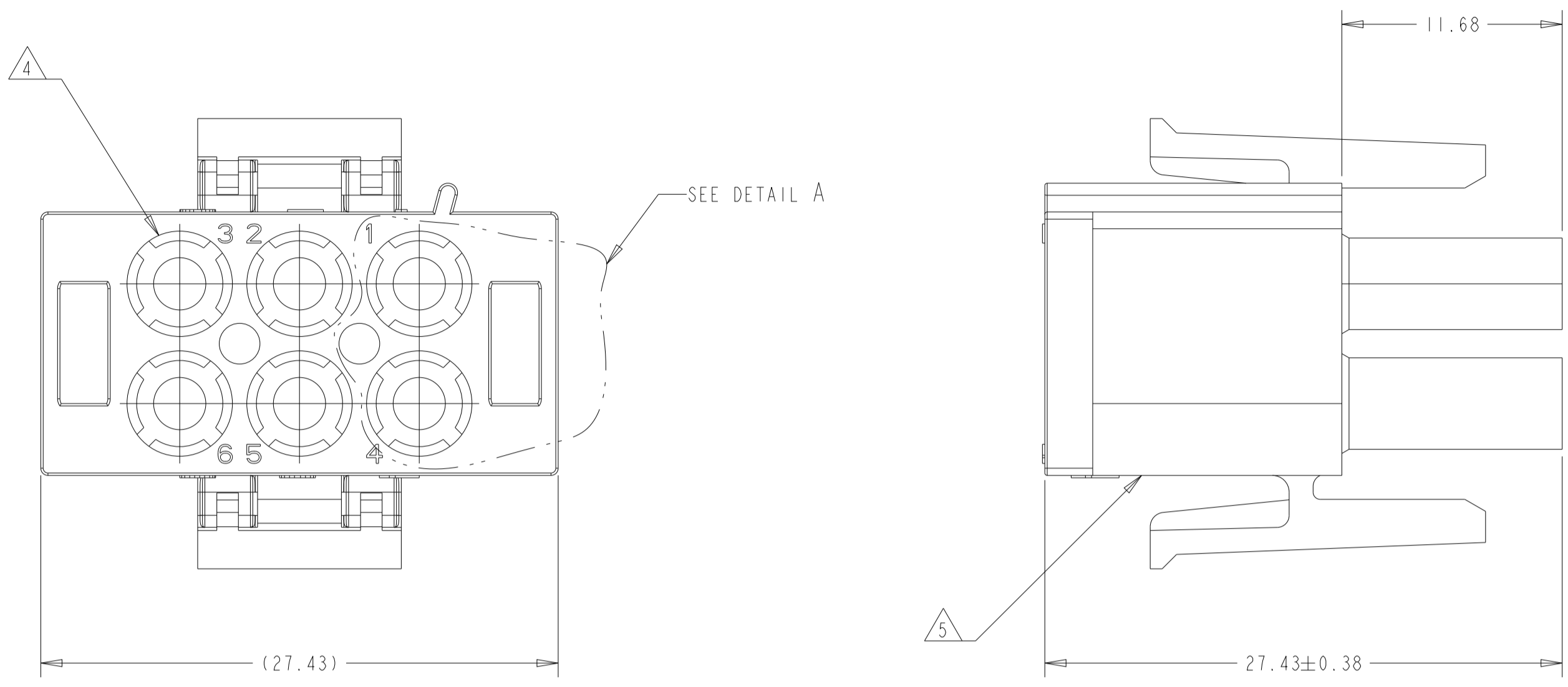
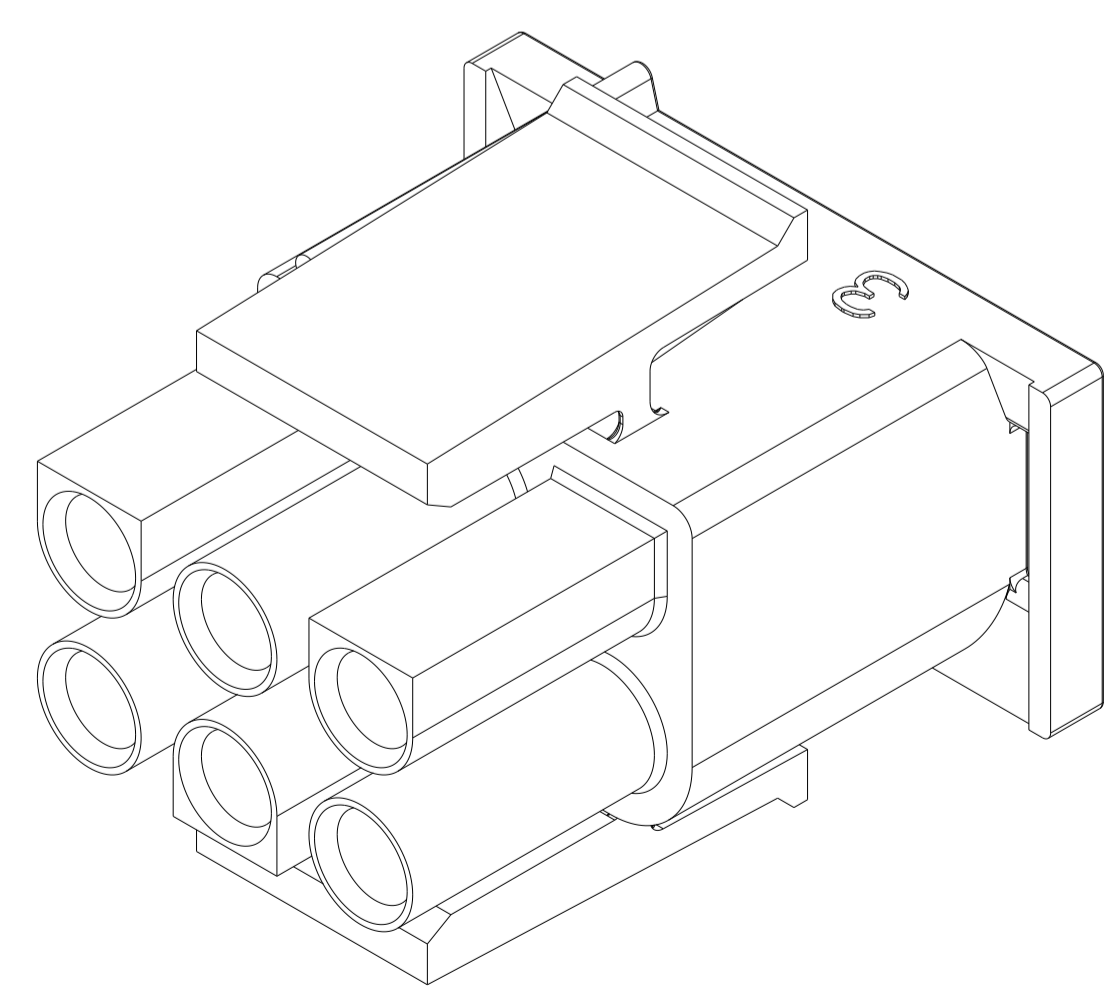

MM	IN
27.43	1.080
20.32	.800
13.97	.550
11.68	.460
0.38	.015
0.13	.005
MM	IN

CONVERSION TABLE

8	OBsolete	BLACK	1-480704-9
8	OBsolete	GRAY	1-480704-8
8	SUPERSEDED BY 1-480704-0	BLUE	1-480704-6
8	OBsolete	GREEN	1-480704-5
8	OBsolete	YELLOW	1-480704-4
8	OBsolete	ORANGE	1-480704-3
		RED	1-480704-2
		BROWN	1-480704-1
		NATURAL	1-480704-0
		COLOR	PART NUMBER

THIS DRAWING IS A CONTROLLED DOCUMENT.

DIMENSIONS:	TOLERANCES UNLESS OTHERWISE SPECIFIED:	DWN K. WHITAKER 23MAR2005	NAME PLUG, 6 CIRCUIT, UNIVERSAL MATE-N-LOK
mm	0 PLC ± 1 PLC ± 2 PLC ±0.13 3 PLC ± 4 PLC ± ANGLES ±40°30'	CHK S. RIDGILL 23MAR2005	SIZE A
MATERIAL NYLON, UL 94V-2	FINISH	APVD S. RIDGILL 23MAR2005	CAGE CODE 00779
		PRODUCT SPEC	DRAWING NO 480704
		APPLICATION SPEC	RESTRICTED TO
		WEIGHT	SHEET 1 OF 2
		CUSTOMER DRAWING	REV AS

SCALE 4:1

REVISIONS				
P	LTN	DESCRIPTION	DATE	APVD
-		SEE SHEET 1	-	-

- MOLD NUMBERS APPROXIMATELY 3mm HIGH AT WIRE END OF HOUSING (12 POINT DAVID TYPE).
- CHARACTERS TO BE POSITIONED ON HOUSING TO BE READ FROM WIRE END ONLY.

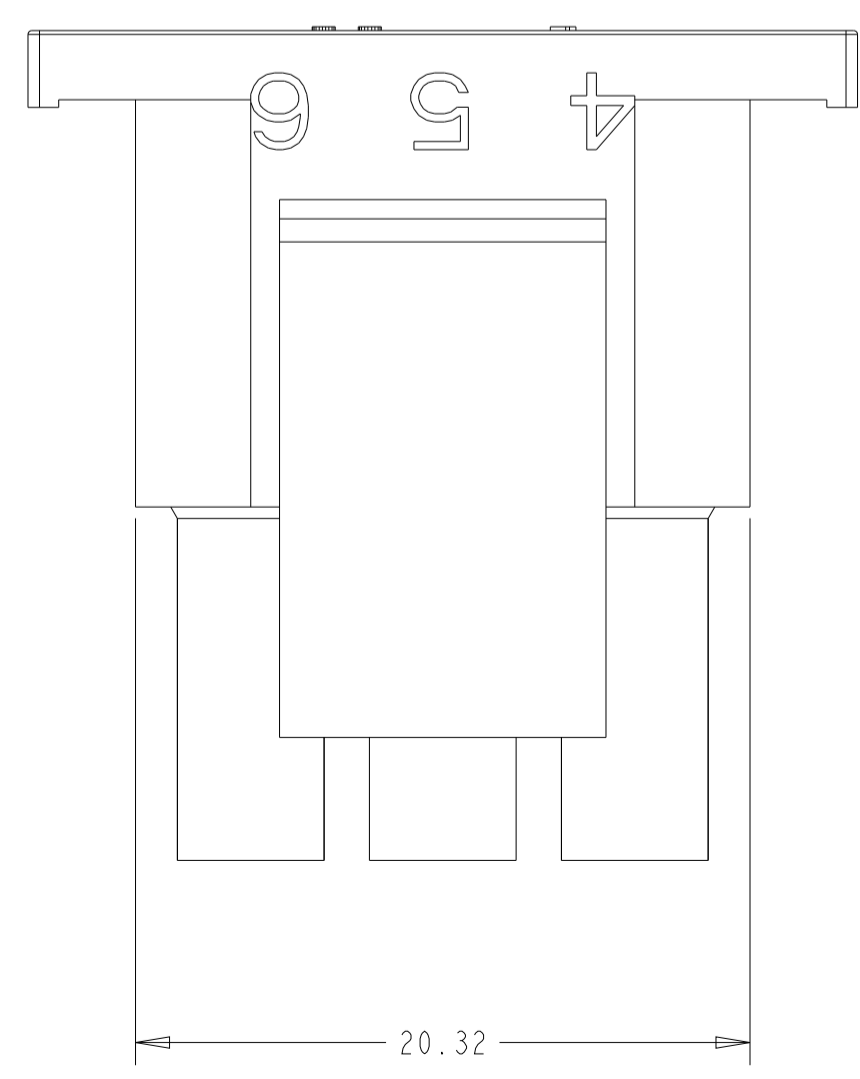
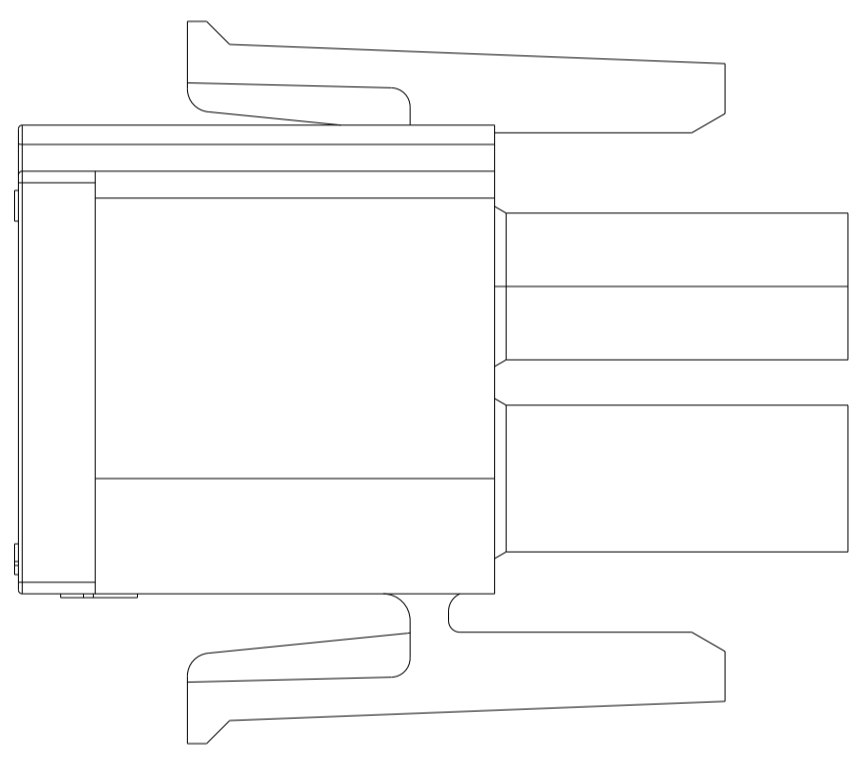
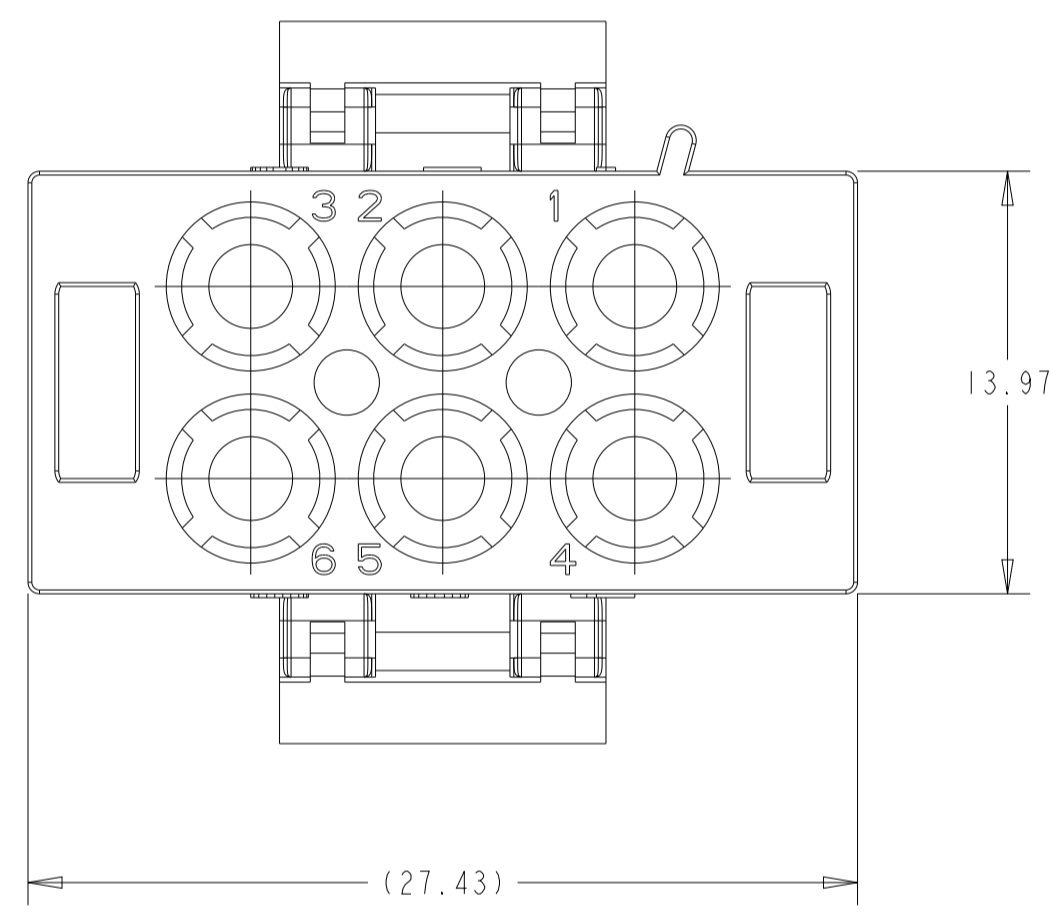
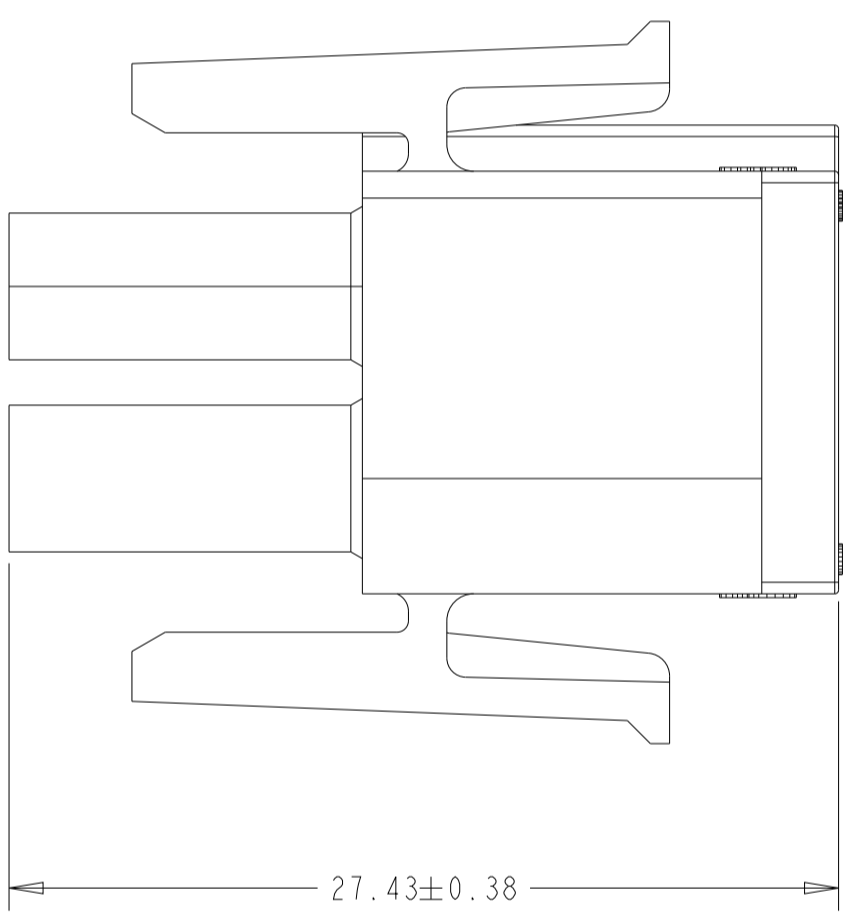
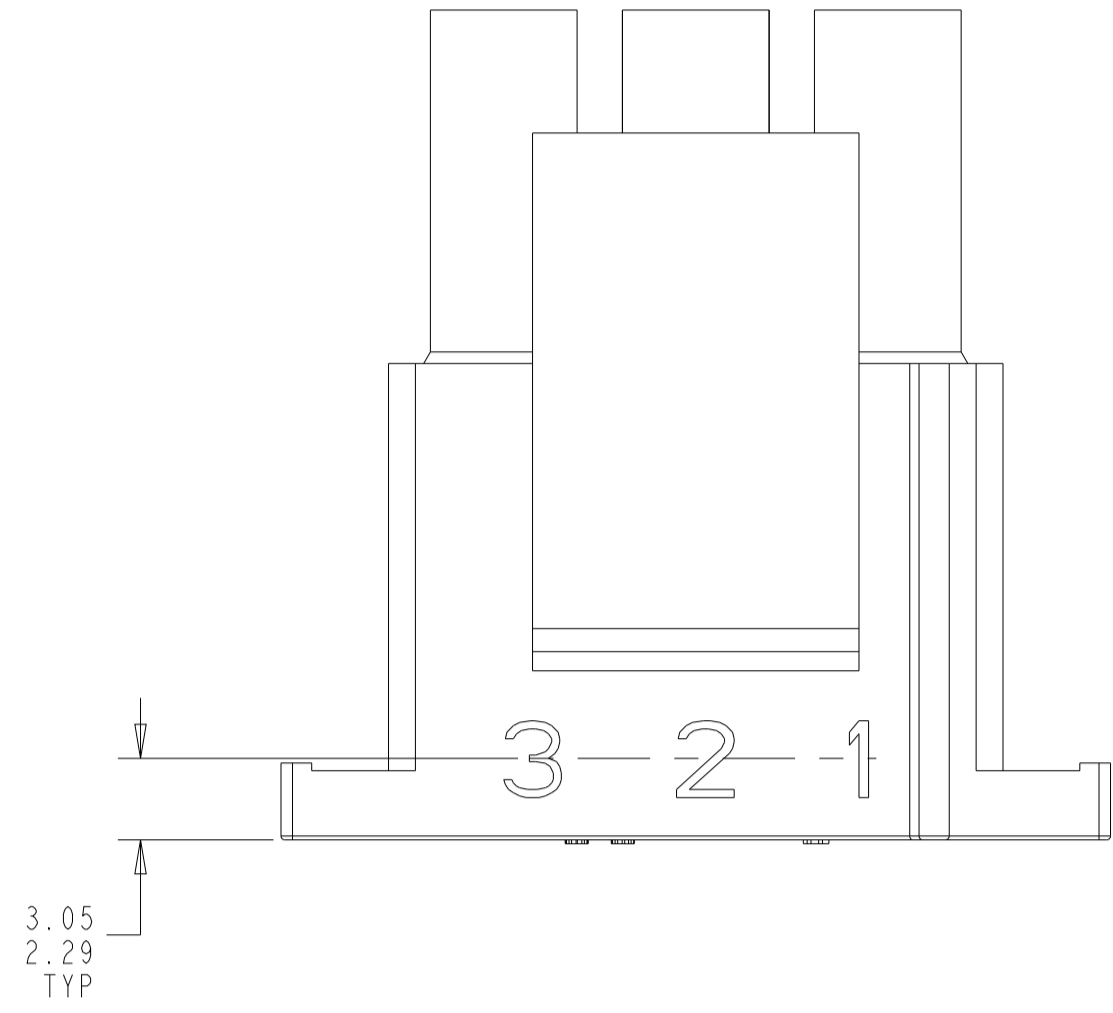

SUPERSEDED BY 1-480704-0 NATURAL COLOR PART NUMBER ~~2-480704-0~~

MM	IN	MM	IN
3.05	.120	27.43	1.080
2.29	.090	20.32	.800
0.38	.015	13.97	.550
0.13	.005	3.18	.125

CONVERSION TABLE

THIS DRAWING IS A CONTROLLED DOCUMENT.		DWN K. WHITAKER 23MAR2005	TE Connectivity	
DIMENSIONS:		CHK S. RIDGILL 23MAR2005	NAME PLUG, 6 CIRCUIT, UNIVERSAL MATE-N-LOK	
TOLERANCES UNLESS OTHERWISE SPECIFIED:		APVD S. RIDGILL 23MAR2005	PRODUCT SPEC	
mm		APPLICATION SPEC		
		SIZE CAGE CODE DRAWING NO		
0 PLC ± 1 PLC ± 2 PLC ±0.13 3 PLC ± 4 PLC ± ANGLES ±40°30'		RESTRICTED TO		
MATERIAL NYLON, UL 94V-2		WEIGHT		
FINISH		A 00779 C=480704		
CUSTOMER DRAWING		SCALE 4:1 SHEET 2 OF 2 REV AS		