

ANTENNA PRODUCTS

DATA SHEET

0.9/1.8/1.9GHz Triple Band Antenna with Cable & Connector for Mobile Application

Preliminary product specification
Supersedes data of 9th Aug., 2004

2004 Aug. 10 Rev. 9

0.9/1.8/1.9GHz Triple Band Antenna with Cable & Connector for Mobile Application Part No. CAN 4313330109191B				4313 330 00919 4313 330 01919 4313 330 03919 4313 330 09919 4313 330 10919			—	6	Mar. 17, 03		
							▶	7	Mar. 26, 03		
							—	8	Aug. 9, 04		
BY	Cliff	SUPER		TLL.SH	8	PAGE	1	SH nr.	—	9	Aug. 10, 04
CHECK				DATE	Aug. 10, 2004			—	▶		

GSM/DCS/PCS (900/1800/1900MHz) Antenna with Connector/Cable

Product Specification¹

QUICK REFERENCE DATA

Frequency Range	GSM900	880-960 MHz
	DCS1800	1710-1880 MHz
	PCS1900	1850-1990 MHz
Peak Gain	GSM900	0~0.5 dBi
	DCS1800/PCS1900	0.5~1 dBi

(Dependent on ground plane size and tuning circuit of customer)

VSWR 3.5 max
(Dependent on ground plane size and after tuning of customer)

Polarization Linear

Impedance 50 Ohm

Operating Temperature -40~85 °C

Size 35X6X0.4 mm

Maximum Power 1W

Antenna Flammability Grade Antenna Patch: UL94V0; Antenna Cable: E56198



MMCX Type

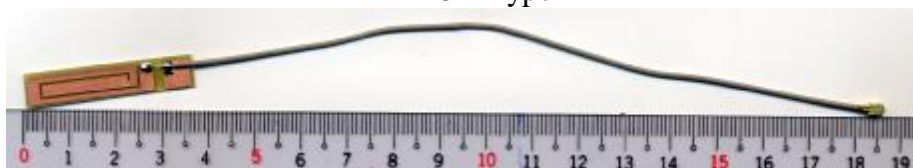

Mini Coaxial/ Mini Connector Type

¹ All the technical data and information contained herein are subject to change without prior notice

0.9/1.8/1.9GHz Triple Band Antenna with Cable & Connector for Mobile Application Part No. CAN 4313330109191B				4313 330 00919 4313 330 01919 4313 330 03919 4313 330 09919 4313 330 10919			—	6	Mar. 17, 03		
							▶	7	Mar. 26, 03		
							—	8	Aug. 9, 04		
BY	Cliff	SUPER		TLL.SH	8	PAGE	2	SH nr.	—	9	Aug. 10, 04
CHECK				DATE	Aug. 10, 2004			—	▶		

DIMENSIONAL DATA and Connector/Cable Information (unit: mm).

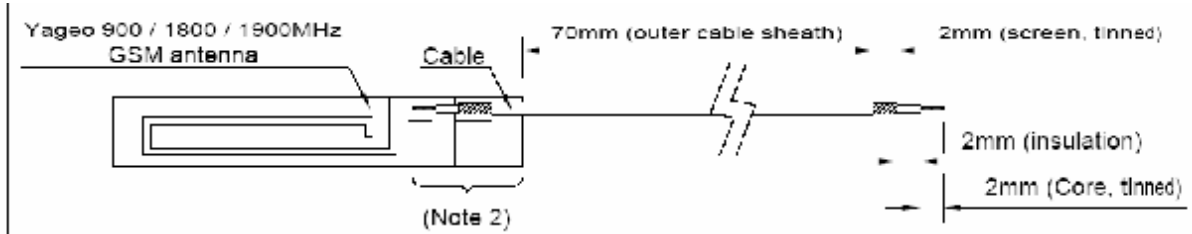

Notes

- 1) This drawing indicates the Technology requirements for the termination of the Yageo supplied 900 / 1800 / 1900MHz antenna.
- 2) The end of the cable connected to the antenna is to be terminated as required by the antenna manufacturer
- 3) Tolerance on all measurements $\pm 0.0mm$

REV.	QMR No.	DATE	TITLE: Yageo antenna cable termination requirements	Technology Ltd., 10a Westside Road, Aldershot, Woking, Surrey GU24 0JF (UK) Tel: +44 (0)1252 829811 Fax: (0)1252 824255 e-mail: technology@technology.com	Yageo Technology Ltd. owns all rights in and to all confidential information. No job spec or technical drawing is to be used or reproduced in any way without the written consent of Yageo Technology Ltd.	DRAWN	M. Jeffcock
A	ORIGINAL	05/06/04				CHECKED	J. Sawyer
B	Tolerance revised to $\pm 0.1mm$	05/06/04				APPROVED	J. Sawyer
						W/O No. ANT_TERM	
						SKILL 1 1 01 1	1/0/0

Tolerance of radiation patch length and width is ± 1 mm and thickness is ± 0.1 mm
 Cable length tolerance is ± 1 mm

APPLICATION IN MOBILE: Place antenna in non-metal positions for best radiation



0.9/1.8/1.9GHz Triple Band Antenna with Cable & Connector for Mobile Application Part No. CAN 4313330109191B				4313 330 00919 4313 330 01919 4313 330 03919 4313 330 09919 4313 330 10919			—	6	Mar. 17, 03	
							▶	7	Mar. 26, 03	
							—	8	Aug. 9, 04	
							▶	9	Aug. 10, 04	
BY	Cliff	SUPER	TLL.SH	8	PAGE	3	SH nr.	—	9	Aug. 10, 04
CHECK				DATE	Aug. 10, 2004			—		

Return Loss Measurement in Mobile Unit (Note: Depending on antenna environment)

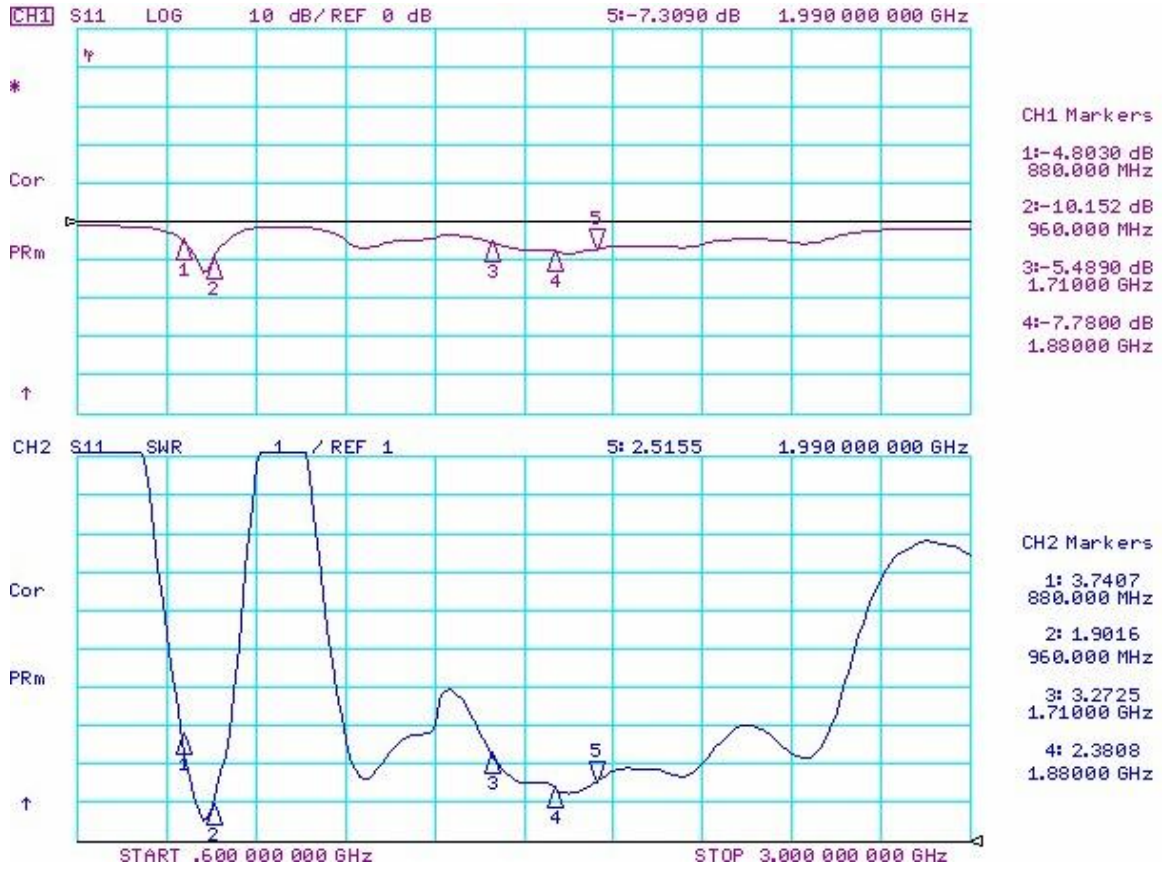

0.9/1.8/1.9GHz Triple Band Antenna with Cable & Connector for Mobile Application Part No. CAN 4313330109191B				4313 330 00919 4313 330 01919 4313 330 03919 4313 330 09919 4313 330 10919			—	6	Mar. 17, 03
							▶	7	Mar. 26, 03
							—	8	Aug. 9, 04
							▶	9	Aug. 10, 04
BY	Cliff	SUPER	TLL.SH	8	PAGE	4	SH nr.		
CHECK				DATE	Aug. 10, 2004				

Radiation Pattern Polar Plot (Note: Depending on antenna environment)

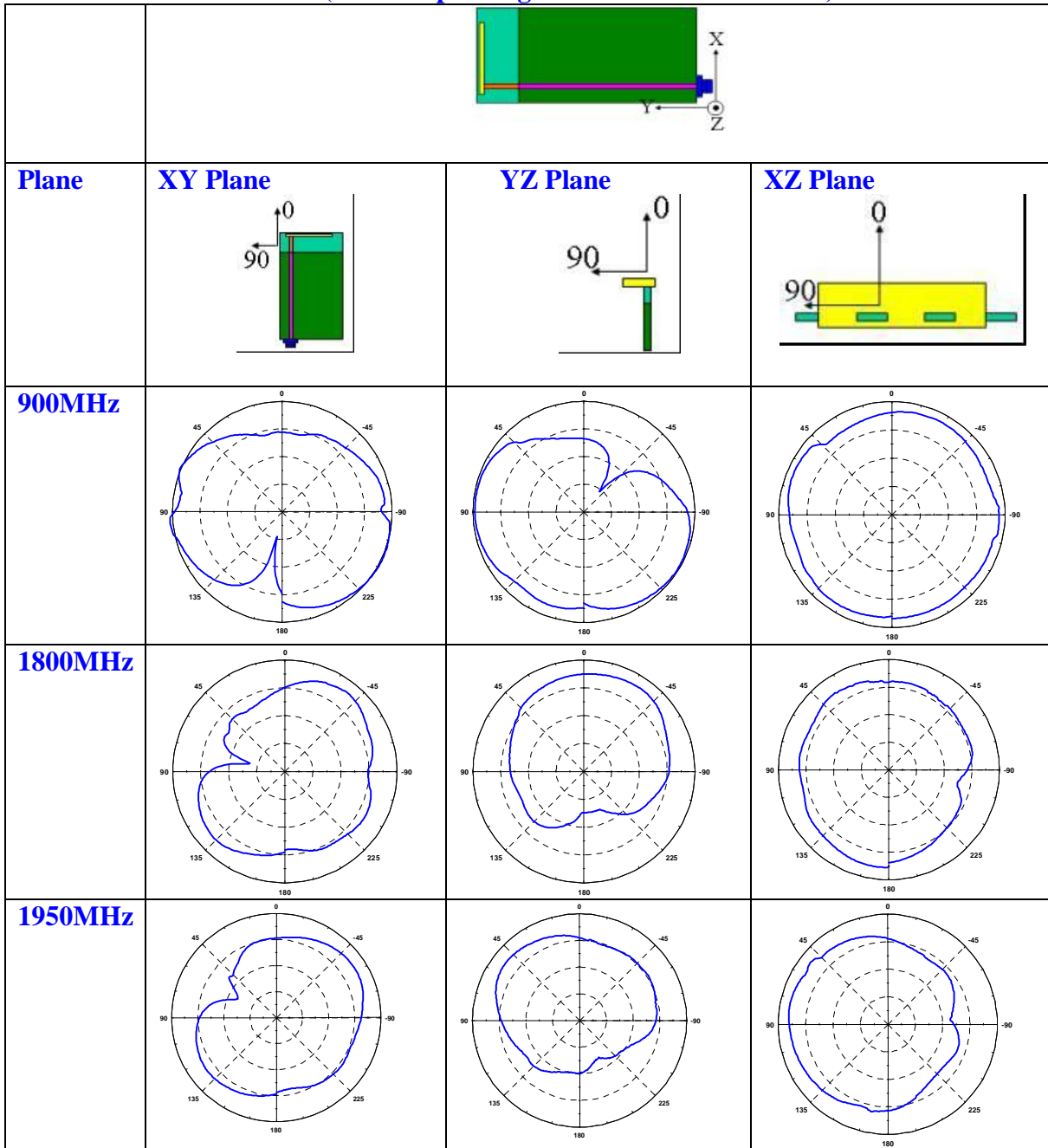

0.9/1.8/1.9GHz Triple Band Antenna with Cable & Connector for Mobile Application Part No. CAN 4313330109191B				4313 330 00919 4313 330 01919 4313 330 03919 4313 330 09919 4313 330 10919			—	6	Mar. 17, 03	
							▶	7	Mar. 26, 03	
							—	8	Aug. 9, 04	
							▶	9	Aug. 10, 04	
BY	Cliff	SUPER		TLL.SH	8	PAGE	5	SH nr.	—	
CHECK				DATE	Aug. 10, 2004			—		

RELIABILITY DATA (Reference to IEC Specification)

IEC 384-10/CECC 32 100 CLAUSE	IEC 60068-2 TEST METHOD	TEST	PROCEDURE	REQUIREMENTS
4.5		Visual inspection and dimension check	Any applicable method using $\times 3$ magnification	In accordance with specification (pcb damage 2 mm)
4.6.1		Antenna	Frequency = 0.9/1.8/1.9 GHz; Triple Band	Standard test board
4.8		Adhesion	A force of 5 N applied for 10 s to the line joining the terminations and in a plane parallel to the substrate	No visible damage
4.12	4(Na)	Rapid change of temperature	-40 °C (30 minutes) to +80 °C (30 minutes); 5 cycles	No visible damage Central Freq. Change $\pm 6\%$
4.14	3(Ca)	Damp heat	500 \pm 12 hours at 60 °C; 90 to 95 % RH	No visible damage 2 hours recovery Central Freq. Change $\pm 6\%$
4.15		Endurance	500 \pm 12 hours at 80 °C;	No visible damage 2 hours recovery Central Freq. Change $\pm 6\%$

0.9/1.8/1.9GHz Triple Band Antenna with Cable & Connector for Mobile Application Part No. CAN 4313330109191B				4313 330 00919 4313 330 01919 4313 330 03919 4313 330 09919 4313 330 10919			—	6	Mar. 17, 03		
							▶	7	Mar. 26, 03		
							▶	8	Aug. 9, 04		
BY	Cliff	SUPER		TLL.SH	8	PAGE	6	SH nr.	—	9	Aug. 10, 04
CHECK				DATE	Aug. 10, 2004			—	▶		

ORDERING INFORMATION:

The antennas may be ordered by the following ordering code. These code numbers can be determined by the following rules:

CAN4313 3 30 10 919 1B
 F C M S T A C

F. Family Code C. Packing Type Code M. Materials Code
CAN43 = Antenna **13** = per 1000pcs **3** = FR-4 material (K=4)

S. Size Code
30 = 35 * 6 * 0.4 mm

T. Tolerance and Style
00 = GSM/DCS/PCS Band using 1.13 mm cable with IpeX connector, 15 cm
01 = GSM/DCS/PCS Band using 1.13 mm cable with Right Angle MMCX connector, 20 cm (actual 20.8 cm)
03 = GSM/DCS/PCS Band using 1.13 mm cable with MMC card, 5.3 cm (actual 6.3 cm)
09 = GSM/DCS/PCS Band using 1.13 mm cable with IpeX/HRS connector, 3.8 cm (actual 3.8 cm)
10 = GSM/DCS/PCS Band using 1.13 mm cable without connector, 7 cm outer cable (actual around

A. Working Frequency
919 = GSM 900 880-960 MHz, DCS 1800 1710-1880 MHz
 PCS 1900 1850-1990 MHz

C. Packing Type Code
 1B: 1000 pcs in bulk/bag

0.9/1.8/1.9GHz Triple Band Antenna with Cable & Connector for Mobile Application Part No. CAN 4313330109191B				4313 330 00919 4313 330 01919 4313 330 03919 4313 330 09919 4313 330 10919			—	6	Mar. 17, 03		
							▶	7	Mar. 26, 03		
							▶	8	Aug. 9, 04		
BY	Cliff	SUPER		TLL.SH	8	PAGE	7	SH nr.	—	9	Aug. 10, 04
CHECK				DATE	Aug. 10, 2004			—	▶		

Revision Control:

Revision	Date	Content	Remark
1	Aug. 7, 2002	New Issued	
2	Oct. 17, 2002	Modify Hirose/Ipex or MMCX connector using 1.13 mm cable	
3	Jan. 30, 2003	Add Hirose/Ipex or MMCX connector using 1.13 mm cable, 30 cm CTC and 12NC	
4	Mar.10, 2003	Add MMC Card, 53 cm	
5	Mar.13, 2003	Add 30 cm cable and PCB only and 10cm coding	
6	Mar.17, 2003	Add 130 cm cable MMCX coding	
7	Mar.26, 2003	Add 30 cm cable MMCX coding	
8	Aug.9, 2004	Add 3.8 cm cable Hirose/Ipex connector	
9	Aug.10, 2004	Add 7 cm outer cable without connector	

0.9/1.8/1.9GHz Triple Band Antenna with Cable & Connector for Mobile Application Part No. CAN 4313330109191B				4313 330 00919 4313 330 01919 4313 330 03919 4313 330 09919 4313 330 10919				—	6	Mar. 17, 03	
								▶	7	Mar. 26, 03	
								—	8	Aug. 9, 04	
BY	Cliff	SUPER		TLL.SH	8	PAGE	8	SH nr.	—	9	Aug. 10, 04
CHECK				DATE	Aug. 10, 2004			—			