

Graissage axe galet Avec MOBIL GREASE 28
de chaque cotes de la chape du poussoir

Nota

83 161 874 (SP 9604 00 avec 1x831618 1 W3 SP 9603-10)

*Versions seules autorisees :

- | | |
|----------------------|---|
| - 83 161 1 | Fonction
et connexions
a la demande |
| - 83 161 6 | |
| - 83 161 8 SP9603-10 | |

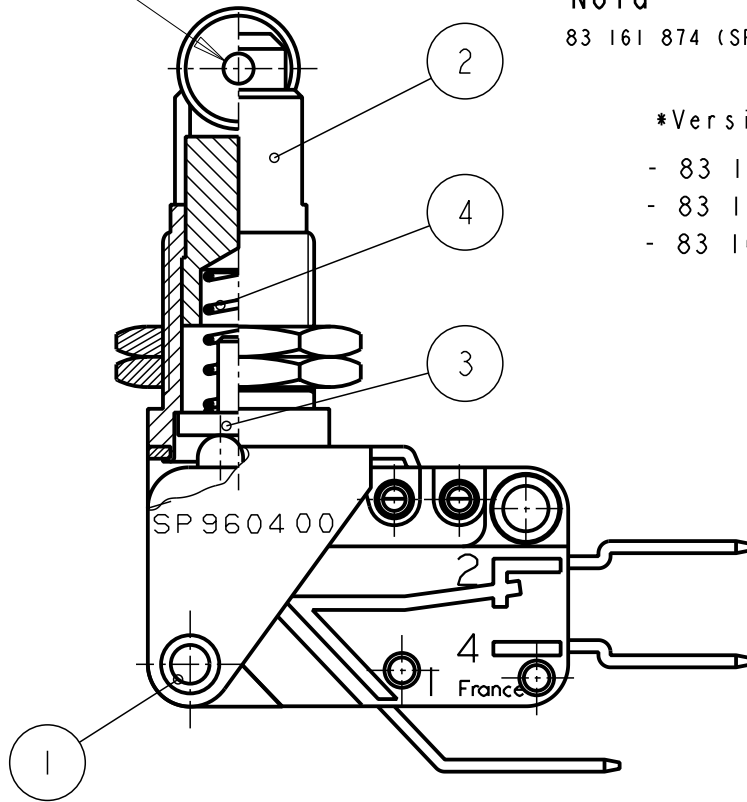

Le canon doit etre relie a la masse

Designation	Reference	Qte	Rep.	Designation	Reference	Qte	Observations
			4	Ressort	79250888	1	
			3	Pompe	79250950	1	
			2	Ensemble chape	79250856	1	
			1	Rivet creux	21163740	1	

- Native Product(s): 83 161 *		+ Product Number: Voir nota	
-------------------------------	--	-----------------------------	--

The product datas and dimensions not specified on this document are similar to native product.

Plan de marquage 7921520563

Suivant C.CI.MI61.SC.0042

Special characteristics

D	PLAN REFAIT SUR PROE . ANNULE PLAN SP960400	Modified by	M_LASCOMBE	16/07/2001
	NOTE DE LANCEMENT DU FILM 7921520563	Verified by	E_GAUTHIER	16/07/2001
		Authorized by	NA	

Toler. gene. lin ±	mm
Toler. gene. Ang ±	degres

This document is the property of Crouzet-Automatismes. It's contents cannot be reproduced or divulged without the company's written approval. The product data and specifications found on this document do not constitute any contractual obligation. Crouzet-Automatismes and its subsidiaries reserve the right to modify the specifications. All rights of reproduction, modification, reprinting, and translation reserved for all countries.

Scale
2/1



General Raw surface Ra ✓

Customer: Tout client Customer Ref.:

10, rue du Dr ABEL BP 59, 26902, VALENCE Cedex 9
Designation/FR: **FICHE TECHNIQUE** PFT001:0<C>;0<M>
Designation/GB: Dispatching **D9**

Department:	Design by C.MINODIER 02/07/1993	DATA SHEET SPECIAL PRODUCT	N°REV	Format	Folio
	Verif. by C.HARMONIE 10/09/1993		SP960400	D	A4
NATO code: FAOX2	Authorized by NA				