

# 2JCP2543G

<b>Type</b>	Ceramic Patch
<b>Frequencies</b>	GPS/GLONASS (1592MHz/1621.96MHz)
<b>Mounting</b>	Through hole
<b>Revision</b>	00



## Application

Navigation  
Embedded

# 1. SPECIFICATIONS

## 1.1. Electrical Specifications

<b>2JCP2543G</b>	
Frequency	1592±3 and 1621.96±3 MHz
Gain	3 dBiC
VSWR	<1.5:1 at center
Impedance	50 Ohms
Polarization	RHCP
Axial ratio	3.0
Frequency Temperature Coefficient	20ppm/deg.°C max

## 1.2. Mechanical Specifications and Dimensions

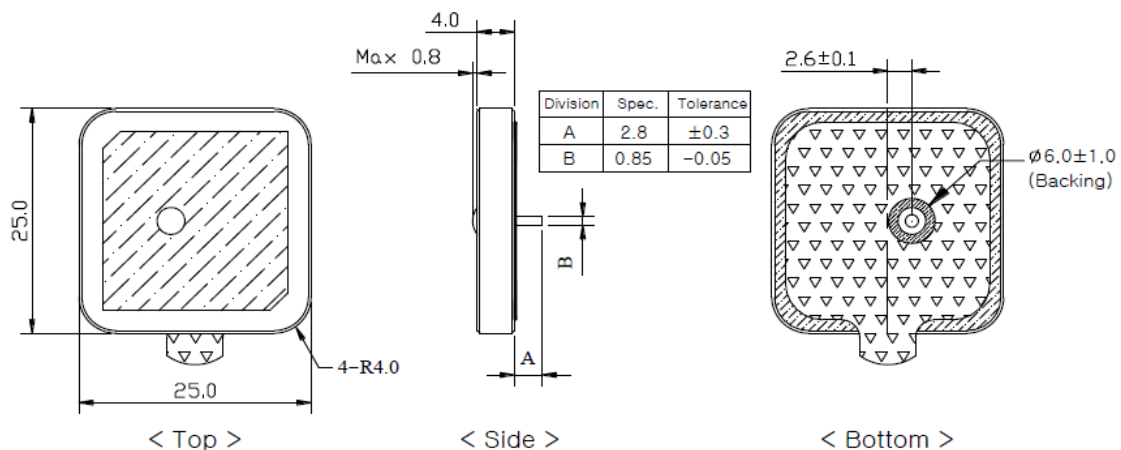

**Note**

1. Unit : mm
2. X.X : ±0.2
3. All Around Both Sides Max. 0.3 Chamfer

No	Item	Specification	Unit	Remarks
1	Dielectric constant	20.5 ± 0.5	-	-
2	Temperature coefficient	0 ± 10	ppm/°C max.	-
3	Electrode	Silver	-	-
4	Probe	Stannum	-	A-1 (7mm)
5	Tape	Double sided adhesive tape	-	25 3M 468MP

## 2. MEASUREMENT

### 2.1. SET for Measurement

Parts shall be measured under a condition (Temp.: $20^{\circ}\text{C}\pm 15^{\circ}\text{C}$ , Humidity :  $65\%\pm 20\%$  R.H.).

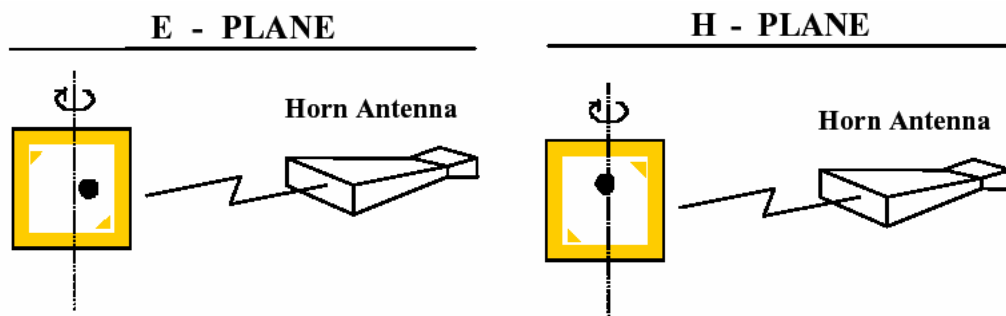
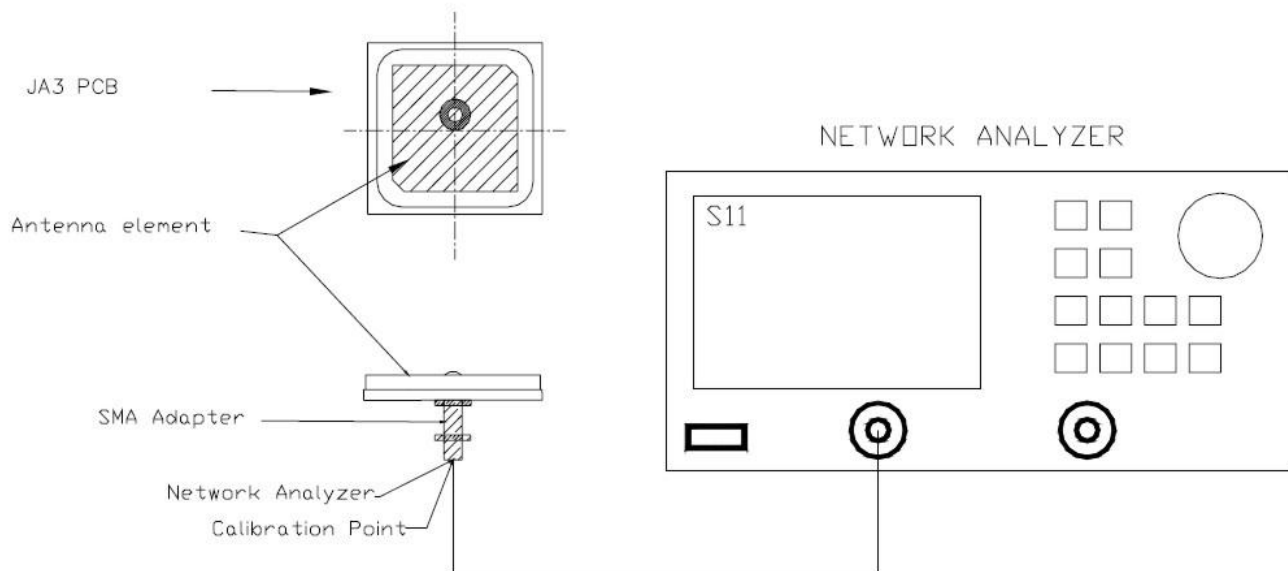

## 2.2. Electrical Characteristics

### 2.2.1. Return Loss & Impedance Characteristic

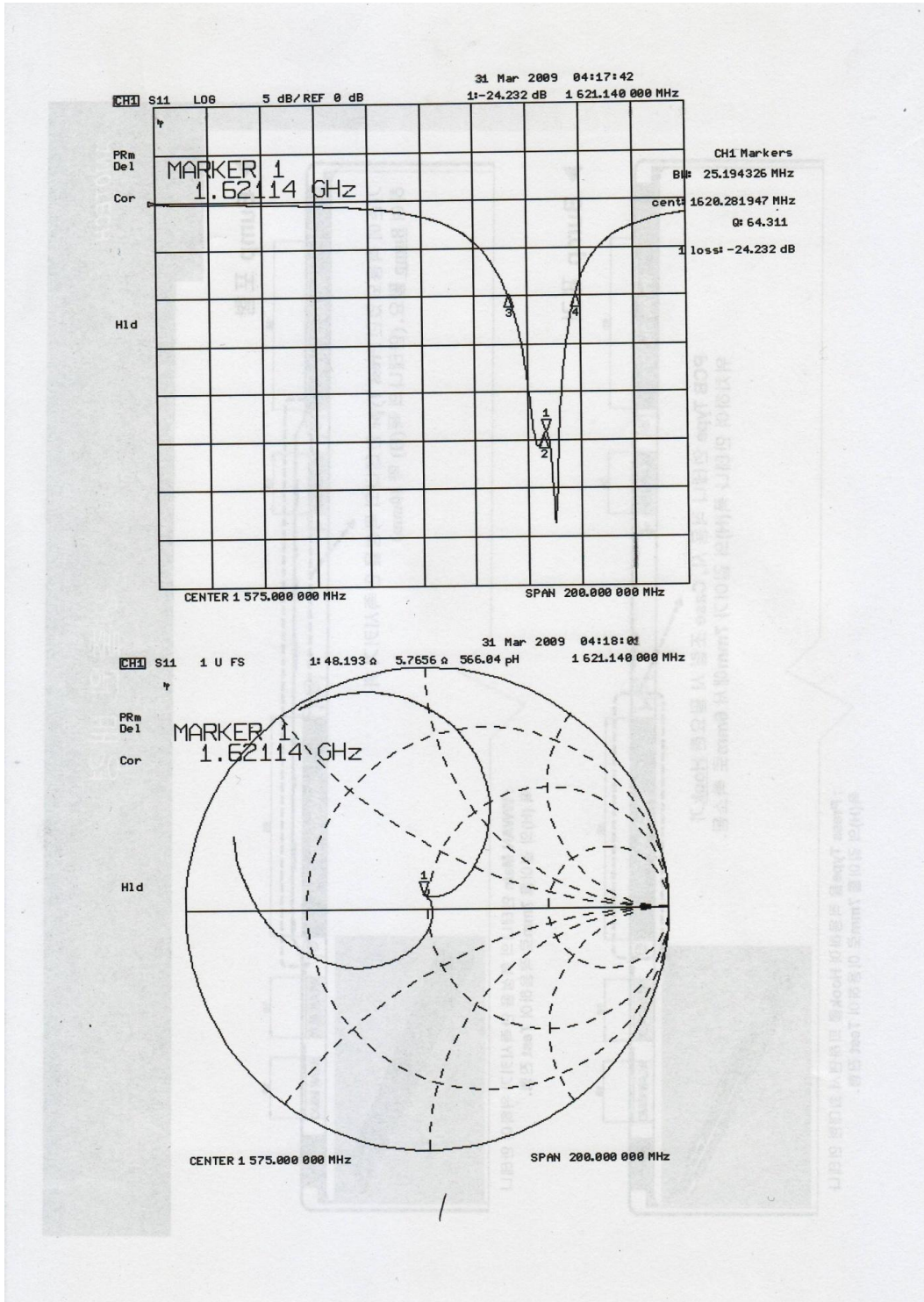

### 2.3. Enviromental Test

6.1	Humidity Test	The device is subjected to 90%~95% relative humidity 60°C±3°C for 96h~98h, then dry out at 25°C±5°C and less than 65% relative humidity for 2h~4h. After dry out the device shall satisfy the specification in table 1.	It shall fulfill the specifications in Table 1.
6.2	High Temperature	The device shall satisfy the specification in table 1 after leaving at 105°C for 96h~98h, provided it would be measured after 2h~4h leaving in 25°C±5°C and less than 65%	It shall fulfill the specifications in Table 1.
6.3	Low Temperature	The device shall satisfy the specification in table 1 after leaving at -40°C for 96h~98h, provided it would be measured after 2h~4h leaving in 25°C±5°C and less than 65% relative humidity.	It shall fulfill the specifications in Table 1
6.4	Temperature Cycle	Subject the device to -40°C for 30 min. followed by a high temperature of 105°C for 30 min cycling shall be repeated 5 times. At the room temperature for 1h prior to the measurement.	It shall fulfill the specifications in Table 1.
6.5	Vibration	Subject the device to vibration for 2h each in x, y and z axis with the amplitude of 1.5mm, the frequency shall be varied uniformly between the limits of 10Hz~55Hz.	It shall fulfill the specifications in Table 1.
6.6	Soldering Test	Lead terminals are heated up to 350°C±10°C for 5s±0.5 s with brand iron and then element shall be measured after being placed in natural conditions for 1 h. No visible damage and it shall fulfill the specifications in Table 1	It shall fulfill the specifications in Table 1.
6.7	Solder ability	Lead terminals are immersed in soldering bath of 260°C~290°C for 3s±0.5s . More than 95% of the terminal surface of the device shall be covered with fresh solder.	The terminals shall be at least 95% covered by solder.
6.8	Terminal Pressure Strength	Force of 2kg is applied to each lead in axial direction for 10s±1 s (see drawing). No visible damage and it shall fulfill the specifications in Fig 1	Mechanical damage such as breaks shall not occur.

TABLE 1

Item	Specification After Test (MHz)
Center Frequency change	$\pm 2.0$
-10dB Bandwidth Change	$\pm 2.0$

FIG 1

