



Pouch-Cell HCB903048

Advantages

- **Highly Flexible and Customizable** (size and model can be customized, square ultra-thin structure, maximizing the use of battery compartment)
- **Good Safety Performance** (soft aluminum plastic film shell, safer than ordinary steel and aluminum shell batteries)
- **High Capacity** (compared with steel and aluminum prismatic batteries of the same size, the capacity can be increased by 5%~15%)
- **Light Weight, High Specific Energy** (mass specific energy can reach 250Wh/kg)

Application

- Smart Wearable Devices
- GPS Tracker
- Portable Power Bank
- Portable Medical Devices
- Electric Two Wheeler

Electrical Performance Parameters

Product Series:	HCB Li-ion Battery
Nominal Capacity	1500 mAh
Minimum Capacity	1400 mAh
Nominal Voltage	3.7 V
Discharge Cut-off Voltage	2.8 V
Charge Cut-off Voltage	4.2 V
Cycle life (0.2C 100%DOD)	≥500
Maximum Continuous Discharge Current	1500 mA
Standard Discharge Current	160 mA
Maximum Charge Current	800 mA
Internal Resistance(1kHz@RT)	≤170mΩ

Storage Environment (Recommended)

25±3°C 65±20% RH

Operating Temperature

Charge Temperature 0°C~45°C

Discharge Temperature -20°C~60°C



Pouch-Cell

HCB903048

PCM Specification

IC:	CM1002-ZA	parameter value			
Protection IC:		General temperature 25°C			
item	Min.	Type value	Max.	Unit	
Over charge protection voltage	4.225	4.250	4.275	V	
Over charge release voltage	4.100	4.150	4.200	V	
Over discharge protection voltage	2.720	2.800	2.880	V	
Over discharge release voltage	2.900	3.000	3.100	V	
Discharge overcurrent detection voltage	0.120	0.150	0.180	V	
Discharge overcurrent protection current	2.0	4.0	6.0	A	
Charge overcurrent detection voltage	-0.13	-0.1	-0.07	V	
Charge overcurrent protection current	1.0	2.0	4.0	A	
Over charge protection delay time	40	80	160	ms	
Over discharge protection delay time	20	40	80	ms	
Discharge overcurrent protection delay time	5	10	20	ms	
Charge overcurrent protection delay time	5	10	20	ms	
Short protection delay time	125	280	500	us	
Current consumption (Operation)		1.5	3.0	uA	
Current consumption (Power down)			1	uA	
Impedance		45	65	mΩ	
Input voltage(B+ to B-)	-0.3		8	V	
0V battery charge function	Available				



Pouch-Cell HCB903048

Circuit Diagram

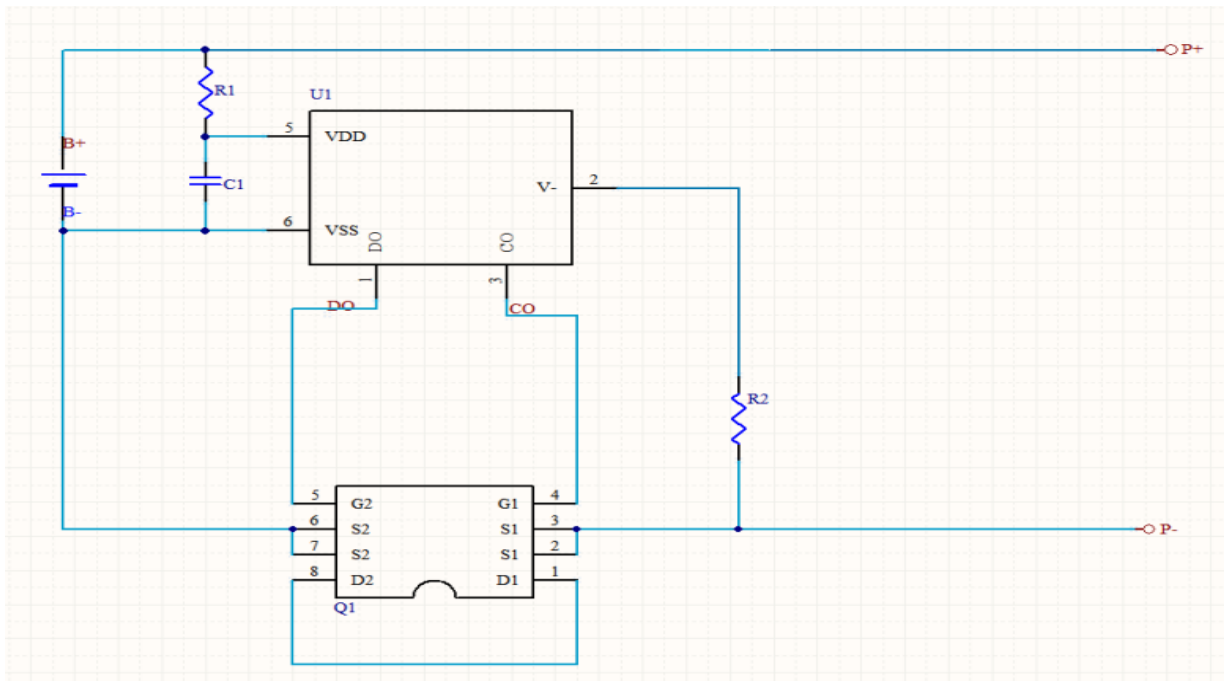

Parts List

Parts	Model	Package	Number	PCS
IC	CM1002-ZA	SOT23-6	U1	1
MOSFET	DP8205A	TSSOP8	Q1	1
Capacitance	0.1uF/+80%-20%/16V	0402	C1	1
Resistance	1KΩ±5%/1/16W	0402	R1	1
Resistance	2KΩ±5%/1/16W	0402	R2	1
PCB	Two layers,tin spraying,1OZ	Green,white text		1



Pouch-Cell

HCB903048

Drawing

