

The thickness of the glue does not exceed the polarizer film.

The non-specified tolerance of dimension is ± 0.3 mm.

1	Lcd Type	HTN,GRAY
2	Viewing Direction	12 O'clock
3	Drive Method	1/4 Duty,1/3Bias
4	Polarizer Mode	Reflective/Positive
5	Operating Voltage	VOP=3.6V
6	Operating Temperature	-40°C ~60°C
7	Storage Temperature	-40°C ~70°C

SCALE:	1/1	UNIT:	mm	MODEL	華凌光電股份有限公司 WINSTAR DISPLAY CO.
REV:	0	PAGE:	1/2	TITLE	LCD MODULE
APPROVED				DWG NO.	T-130620
CHECKED	王敬文 06/13/24'				
DRAWN	Molica 06/13/24'				

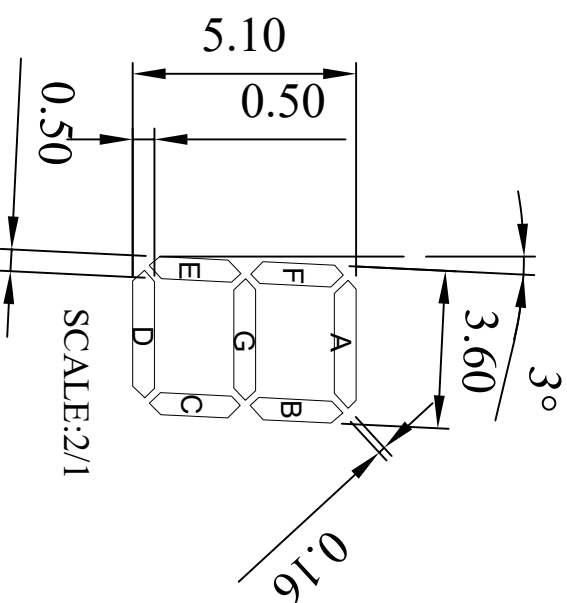
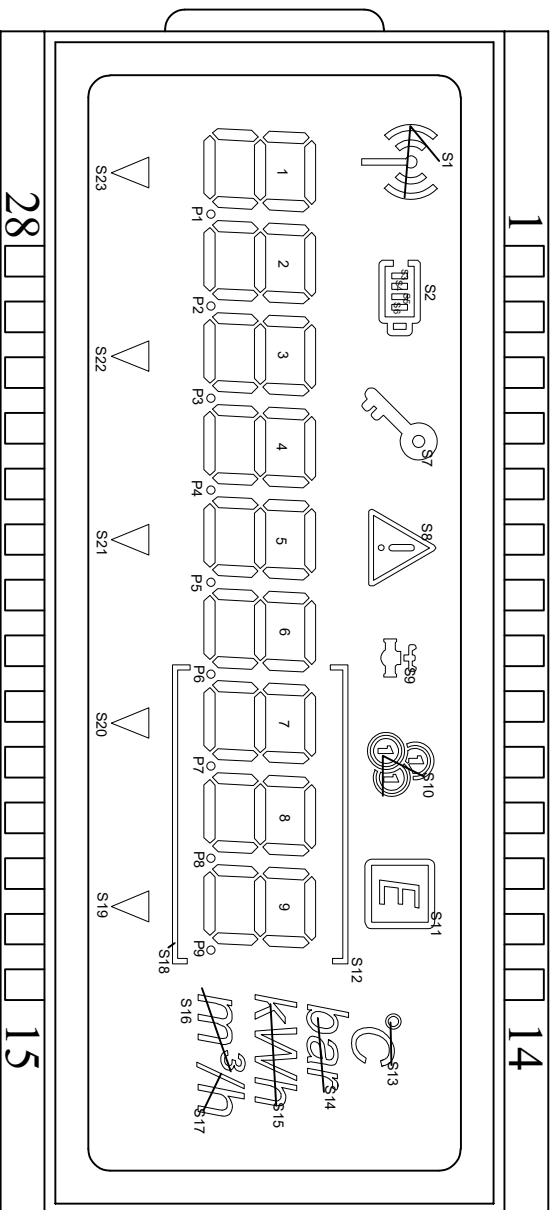

The non-specified tolerance of dimension is ± 0.3 mm.

PIN	1	2	3	4	5	6	7	8	9	10	11	12	13	14
COM1	S5	S6	S12	7A	7B	8A	8B	9A	9B	S13	COM1	--	--	--
COM2	S4	S2	S11	7F	7G	8F	8G	9F	9G	S14	--	COM2	--	--
COM3	S3	S7	S10	7E	7C	8E	8C	9E	9C	S15	--	--	COM3	--
COM4	S1	S8	S9	7D	P7	8D	P8	9D	P9	S17	--	--	--	COM4

PIN	15	16	17	18	19	20	21	22	23	24	25	26	27	28
COM1	S18	6B	6A	5B	5A	4B	4A	3B	3A	2B	2A	1B	1A	--
COM2	S20	6G	6F	5G	5F	4G	4F	3G	3F	2G	2F	1G	1F	S23
COM3	S19	6C	6E	5C	5E	4C	4E	3C	3E	2C	2E	1C	1E	S22
COM4	S16	P6	6D	P5	5D	P4	4D	P3	3D	P2	2D	P1	1D	S21

SCALE:	1/1	UNIT:	mm
REV:	0	PAGE:	2/2
APPROVED	 賴國堅 06/13/24'		
CHECKED	 王敬文 06/13/24'		
DRAWN	 Molicca 06/13/24'		
MODEL	WDN1818-NHD-#00		
TITLE	LCD MODULE		
DWG NO.	T-130620		