

THIS DOCUMENT IS THE PROPERTY OF KEYSTONE ELECTRONICS CORP. AND SHALL NOT BE REPRODUCED, DISTRIBUTED OR USED AS A BASIS FOR MANUFACTURE WITHOUT PRIOR WRITTEN PERMISSION FROM KEYSTONE ELECTRONICS CORP.

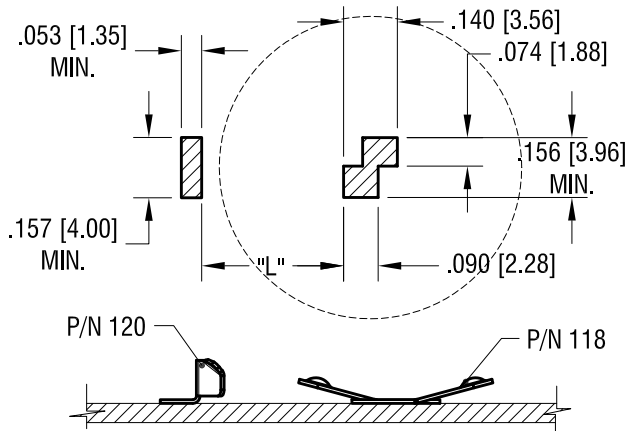

MTG LAY OUT WHEN USE WITH P/N 120

BATTERY DIA.	L
12mm	.178 [4.5]
16mm	.257 [6.5]

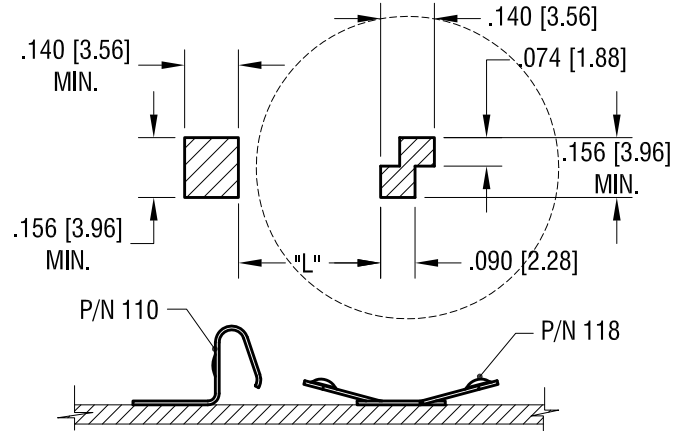

MTG LAY OUT WHEN USE WITH P/N 110

BATTERY DIA.	L
12mm	.213 [5.4]
16mm	.291 [7.4]

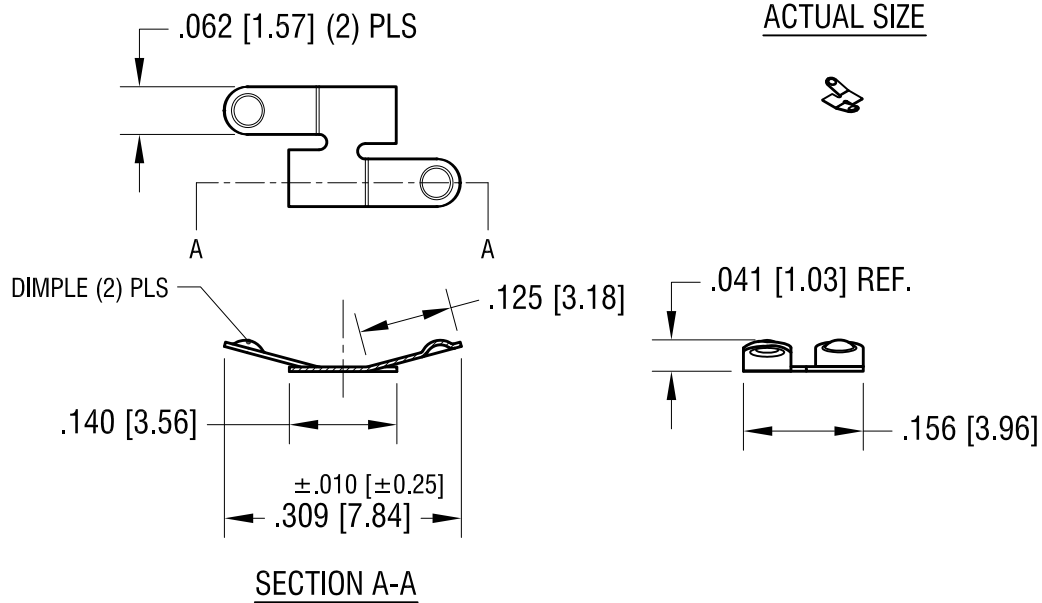

9.21.15	CHANGE AS PER ECN 15-105	A
DATE	DESCRIPTION	REV.

KEYSTONE ELECTRONICS CORP.		
www.keyelco.com • ASTORIA, N.Y. 11105-2017 • Tel (718) 956-8900		
PART NAME		
NEGATIVE BATTERY CONTACT		
MATERIAL		
.006 [0.15] TH'K STAINLESS STEEL		
FINISH		DRN BY
GOLD PLATE		NT
		DATE
		6.23.15
		APP'D
		LN
		SCALE
		4X
TOLERANCES	INCH [MM]	CODE
DECIMAL	± .005 [± 0.13]	DWG NO.
ANGULAR	± 1°	
UNLESS OTHERWISE SPECIFIED		
		118