

**Mini K HV Precharge Relay**

- Suitable for voltage levels up to 450VDC
- Precharge currents up to 20A
- Limiting break currents up to 20A
- Available with PCB and plug-in terminals
- IEC 60664 compliant

Typical applications

DC high voltage precharge applications in hybrid, full battery electric vehicles and fuel-cell cars.



3D700\_fw7co

Contact Data	
Contact arrangement	1 form X (NO DM)
Rated voltage	400VDC
Max. switching voltage <sup>1)</sup>	450VDC
Limiting switching current <sup>2)</sup>	
normal operation	20A on/0A off: min. 10 <sup>5</sup> ops.
fault break operation <sup>3)</sup>	20A on/20A off: min. 10 ops. <sup>3)4)</sup>
Initial contact voltage drop at 10A	typ. 150mV, max. 300 mV
Operate time at nominal voltage	typ. 2.5ms
Release time <sup>5)</sup>	typ. 1ms
Mechanical endurance	>10 <sup>6</sup> ops.

- 1) Consult TE Connectivity for insulation compatibility with higher voltages.
  - 2) Load circuit: L <100µH.
  - 3) After 10 fault break operations relay must be replaced.
  - 4) Test conditions: on-time 100ms, off-time 10s.
  - 5) Valid for recommended 250Ω suppression resistor (PCB version).
- Note: A low resistive suppression device in parallel to the relay coil increases the release time and reduces the lifetime due to increased erosion and / or higher risk of contact tack welding.

Coil Data	
Nominal voltage	12V
Max. energization duration	2s <sup>6)</sup>

6) Max. continuous activation time is limited and depends on operating conditions. Please contact TE Connectivity for details.

Coil versions					
Coil code	Rated voltage VDC	Operate voltage VDC <sup>7)</sup>	Release voltage VDC <sup>7)</sup>	Coil resistance Ω±10%	Rated coil power W
001	12	6.9	1.2	50	2.9
002	12	6.9	1.2	41.6 <sup>8)</sup>	3.5

- 7) All values are given for coil without pre-energization, at ambient temperature +23°C.
- 8) 249 Ohm coil suppression resistor already included.

Coil operating range

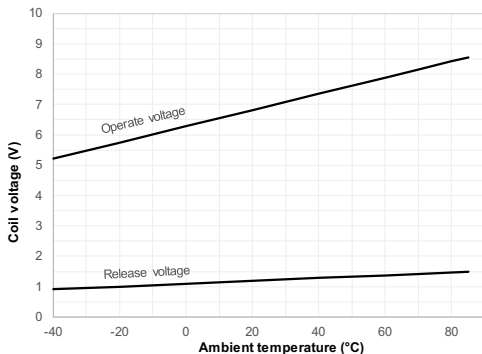

Insulation Data <sup>1)</sup>	
Initial dielectric strength	
between open contacts	2800 VDC/3mA
between contact and coil	2800 VDC/3mA
Insulation resistance after 10 fault break ops. (20A)	
between open contacts	>200MΩ
between contact and coil	>200MΩ
Clearance / creepage	
acc. IEC 60664-1 (2007) for overvoltage category I, pollution degree 2	
Max. altitude <sup>9)</sup>	5500m

Other Data	
EU RoHS/ELV compliance	compliant
Flammability of plastic material	acc. UL94-HB
Ambient temperature range	-40°C to +85°C
Climatic cycling with condensation	
EN ISO 6988	6 cycles, storage 8/16h
Temperature cycling (shock)	
IEC 60068-2-14, Na	10 cycles, -40/+85°C (5°C per min)
Damp heat constant	
IEC 60068-2-3, Ca	56 days, upper air temperature 40°C
Degree of protection PCB version	
IEC 61810	RT II
Corrosive gas	
IEC 60068-2-42	10 days
IEC 60068-2-43	10 days
Wide-band noise	
IEC 60068-2-64	10 to 1000Hz, 30.8m/s <sup>2</sup> 10)
Shock resistance (functional)	
IEC 60068-2-27 (half sine)	11ms, 20g <sup>10)</sup>
Terminal type	PCB and plug-in/QC
Weight	
PCB version:	approx. 17g (0.6oz)
Plug-in version:	approx. 39g (1.4oz)
Solderability (aging 3: 4h/155°C) PCB version <sup>11)</sup>	
IEC 60068-2-20, Ta, method 1	hot dip 5s, 215°C
Resistance to soldering heat PCB version	
IEC 60068-2-20, Tb, method 1A	hot dip 10s, 260°C with thermal screen
Sealing, IEC 60068-2-17 PCB version	Qc, method 2, 1min/70°C
Storage conditions	acc. to DIN EN 60721-3-1 class 1K2

- 9) Creepage and clearance distances fulfill the isolation coordination requirements of IEC 60664 for equipment that is particularly protected against transient overvoltage if the required impulse withstand voltage is less than 2260V.
- 10) No change in the switching state >10µs.
- 11) Pre-heating must not exceed 85°C.

Notes regarding processing of PCB version:

- Coating of relay is not permitted. If coating of PCB is necessary, the area of relay on top and bottom side must be left out.
- Only wave soldering (max. 260°C with thermal screen/10s) is permitted; no reflow or hand soldering.
- Other process temperatures (e.g. drying of PCB after coating) must not exceed 85°.

**Mini K HV Precharge Relay (Continued)**

**Terminal Assignment**

1 form X (NO DM)  
PCB version

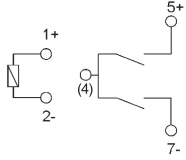

**Dimensions**

PCB version

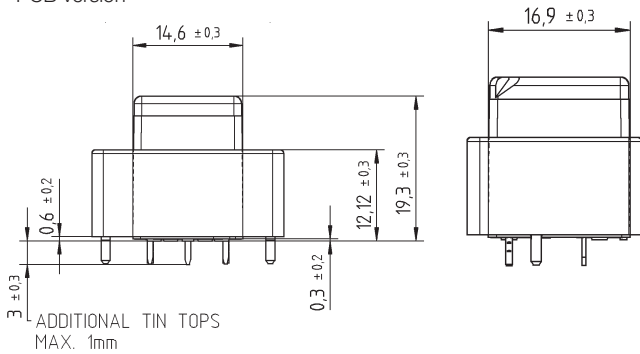

View of the Terminals (bottom view)

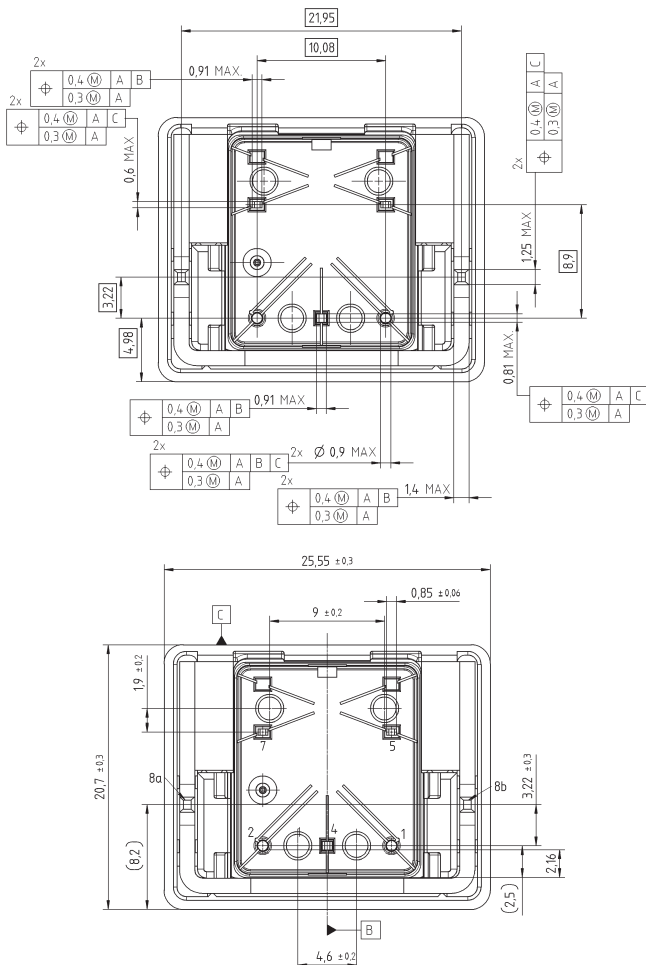

**Terminal Assignment**

1 form X (NO DM) with resistor  
Plug-in version

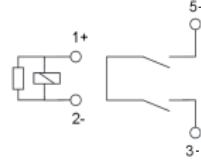

**Dimensions**

Plug-in version

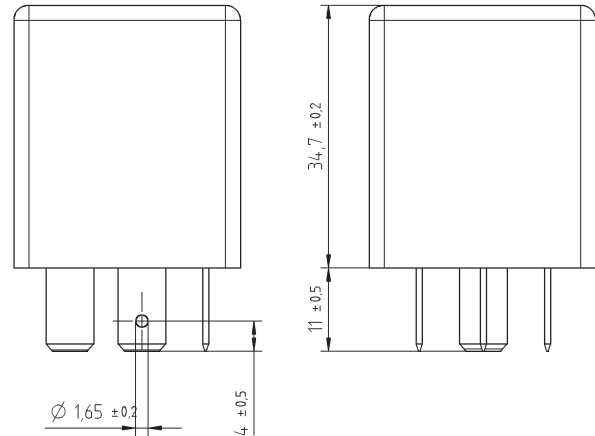

View of the Terminals (bottom view)

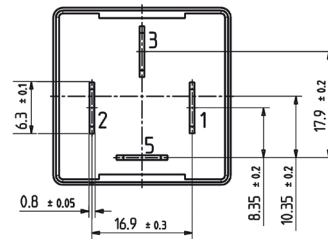

**Recommended relay socket:**  
• TE part number 1-1904045-2

**Suitable crimp terminals:**  
• TE part number 5-160526-9 (coil)  
• TE part number 0-160927-4 (contact)

**Detail PCB version: minimum clearance requirements**

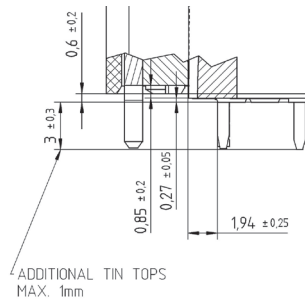

The required clearance and creepage distances between parts connected to HV potential (terminals 4, 5, 7) and parts connected to LV potential (terminals 1,2) must be ensured.

**Notes regarding PCB-layout:**

- Terminal 4 is at HV potential only when the relay is closed. This terminal must not be connected electrically.
- Terminals 8a and 8b are at no electrical potential, but connected internally.

Minimum distance to neighboring ferruginous parts: 3mm.

**Mini K HV Precharge Relay** (Continued)

**Product code structure**

Typical product code

**V23700**

**-C**

**0**

**001**

**-A**

**40**

**8**

**Type**

**V23700** Mini K HV

**Terminal and enclosure**

**C** PCB

**F**

Plug-in

**Design**

**0** Standard

**Coil**

**001** without parallel resistor

**002**

with parallel resistor

**Contact type**

**A** Standard

**Contact material**

**40** Silver based

**Contact arrangement**

**8** 1 form X (NO DM)

Product code	Terminal/Encl.	Design	Coil	Contact type	Contact mat.	Arrangement	Part number
V23700-C0001-A408	PCB, sealed	Standard	without parallel resistor	Standard	Silver based	1 form X (NO DM)	2-1904058-5
V23700-F0002-A408	Plug-in, QC		with parallel resistor				2-1904058-7