

THIS DOCUMENT IS THE PROPERTY OF
KEYSTONE ELECTRONICS CORP. AND
SHALL NOT BE REPRODUCED, DISTRIBUTED
OR USED AS A BASIS FOR MANUFACTURE
WITHOUT PRIOR WRITTEN PERMISSION
FROM KEYSTONE ELECTRONICS CORP.

MOUNTING DETAIL

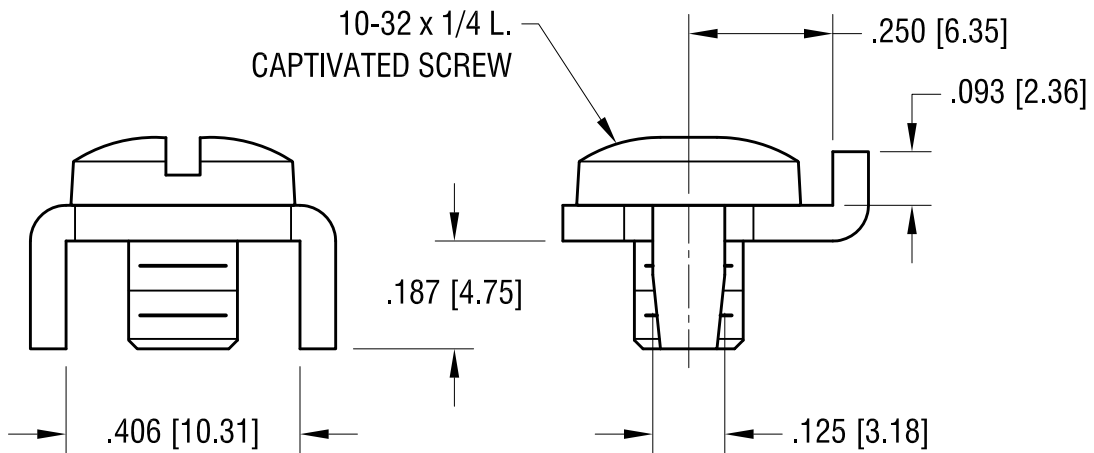
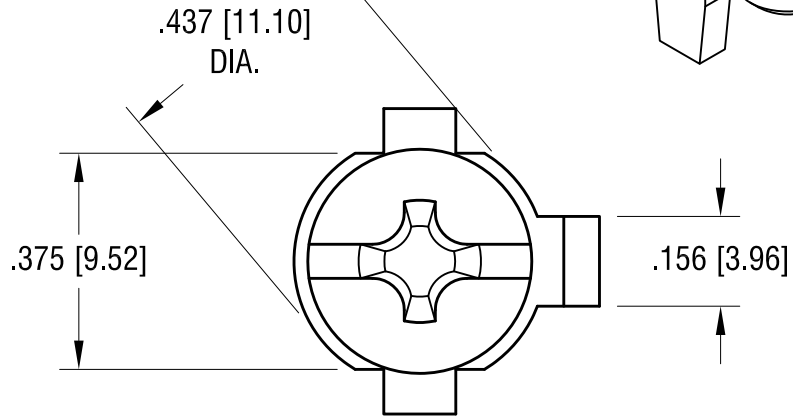
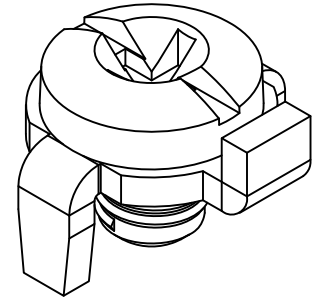
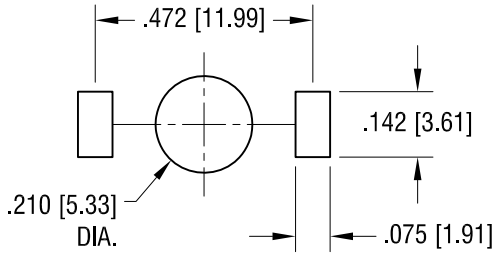

NOTES:

1. TERMINAL:

MAT'L - .062 [1.57] TH'K BRASS, MATTE TIN PLATE

SCREW:

MAT'L - STAINLESS STEEL

FINISH - NONE

7.15.09	CHANGE AS PER ECN 09-102	D
1.9.08	CHANGE AS PER ECN 08-040	C
DATE	DESCRIPTION	REV.

KEYSTONE ELECTRONICS CORP.			
www.keyelco.com • ASTORIA, N.Y. 11105-2017 • Tel (718) 956-8900			
PART NAME		SCREW TERMINAL	
MATERIAL		AS NOTED	
FINISH	AS NOTED	DRN BY	BOONE
		APP'D	LN
		DATE	7.1.99
		SCALE	3X
TOLERANCES	INCH [MM]	CODE	DWG NO.
DECIMAL	± .010 [± 0.25]	C	1202
ANGULAR	± 1°		
UNLESS OTHERWISE SPECIFIED			